

# Old Equipment; New Problem: Solving Legacy Device Issues for a Utility



## Case Study

A public utilities joint operating agency in the Pacific Northwest approached TC Communications about replacing a 30-year-old SONET ring consisting of legacy ADC Magnum 100 multiplexers and Charles D448 channel banks. It needed a solution that would pass dialup services over IP.

While TC Communications helped replace the SONET ring using the TC Communications JumboSwitch, including the [TC3846-6 Dry Contact over IP Gateway](#), the use of the JumboSwitch allowed the customer to address several other needs through the use of other interface cards. The rest of this case study focuses on a sub-project for the customer extending phone lines for public address systems and E&M signaling equipment.

What appeared to be a straightforward solution became more complicated: While testing TC Communications' first solution, the customer ran into technical issues trying to interface with a 40-year-old Tellabs ARD terminate line circuit used for conference calls—a legacy device that TC Communications had not encountered before.

TC test engineers set out to thoroughly reanalyze and retest the customer's system. Despite having little product information, TC Communications was able to provide the customer with a new solution utilizing [TC3848-3/4 Modem over IP Gateway](#) cards, which fully resolved the issue.

## The Application

The customer wanted to extend phone lines for public address systems and E&M signaling equipment at a state Department of Transportation site. The diagram below suggests the application before any TC products:

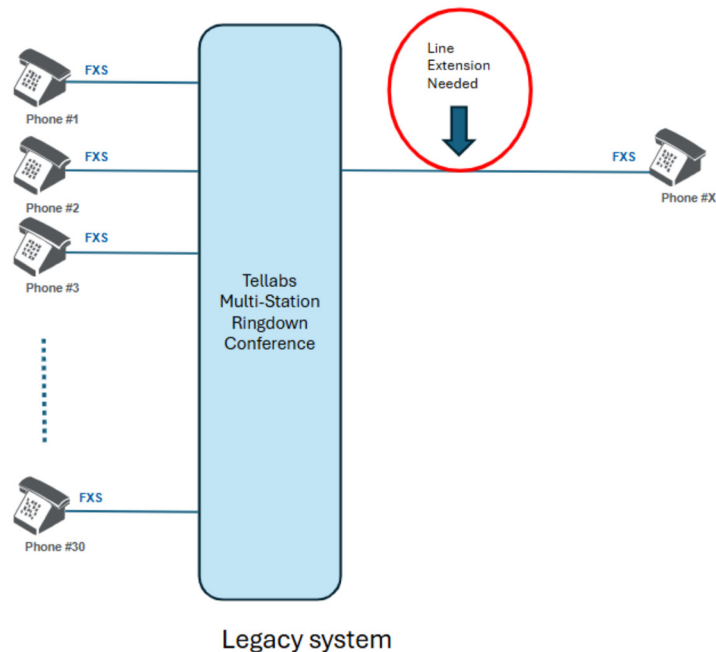

# Old Equipment; New Problem: Solving Legacy Device Issues for a Utility

TC engineers recommended using the [TC3848-1/2 VoIP Virtual PBX](#) cards for their ability to provide four telephone extensions over an Ethernet/IP connection, with the option to scale.

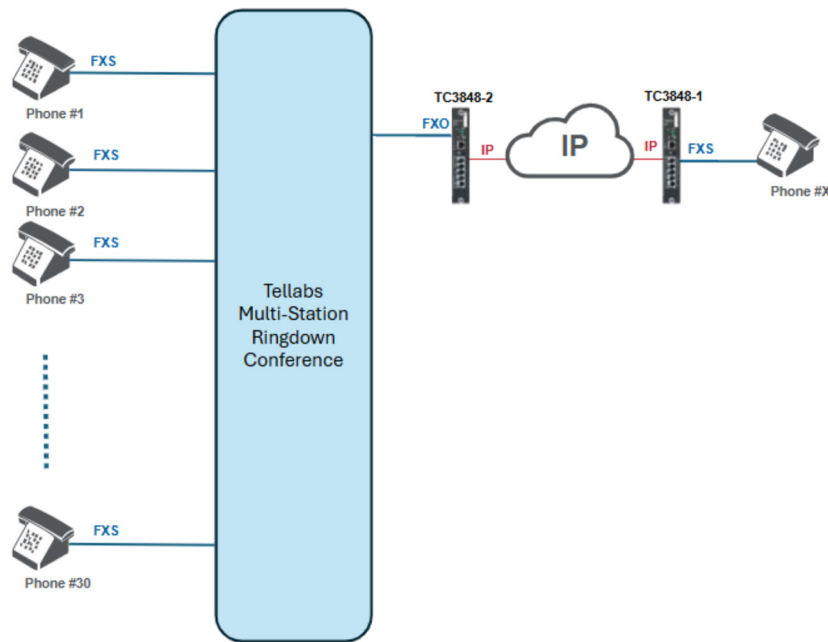

Initial Design using TC3848-1/2

## Unaccountable Busy Tone

TC engineers arranged for onsite training prior to installation, and things went off without a hitch. Days later, however, the customer reported trouble during lab tests with their phone conference bridge, which used classic 2500 Series analog telephone sets.

When the phone connected to the FXO port went off-hook, it would first receive a busy tone and if the receiving phone was not picked up within five seconds, then the line would disconnect.

## Pinpointing the Problem

TC engineers hit the ground running to rereview the customer's system and conducted extensive internal testing for signals.

As it turned out, the culprit was the [Tellabs 9191 Two-Wire ARD \(Automatic Ringdown\) Terminate Line Circuit](#), an obsolete device being used as part of a [Tellabs 291R conference bridge](#) that would allow multiple people to join on one call.

# Old Equipment; New Problem: Solving Legacy Device Issues for a Utility

TC engineers found the issue to be specifically with the FXS port on the 9191 card. Unlike most FXS ports, the FXS port in question provided talk battery only and neither dial tone nor ringing signal. This meant that the TC3848-2 FXO port connected to the 9191 card was unable to detect any loop current after the conference originator hung up. The TC3848-2 FXO port would therefore interpret the line as being connected even though the circuit was in fact open.

## The Real Solution

After looking at the issue, TC engineers determined that [TC3848-3 \(FXS\) and TC3848-4 \(FXO\) Modem over IP Gateway](#) cards were a suitable alternative to the TC3848-1/2 because of their ability to emulate a dedicated phone line.

Part of the problem stemmed from the customer's very old voice system, which required a direct wire from one end to the other. The TC3848-1/2 did not work because they are VoIP products whose hotlink function is different from that of a directly connected wire line. On the other hand, the TC3848-3/4 are TDM over IP products, which offer a pseudo-wire link over Ethernet that emulates a direct wire, eliminating the SIP protocols required for VoIP, including the issuing of a busy signal.

Because a pair of TC3848-3/4 cards can function as an extended two-wire phone line, after the conference originator (FXO side) ends the conference, when the phone on the FXS end is picked up, it recognizes when the FXO end becomes disconnected and remains silent as an open circuit. For this reason, TC engineers determined that the TC3848-3/4 cards would work in this specific application with the 9191 card. This was a unique solution for a Tellabs 9191 ARD card that TC engineers had not seen before.

The diagram below shows the application with the TC3848-3/4 replacing the TC3848-1/2:

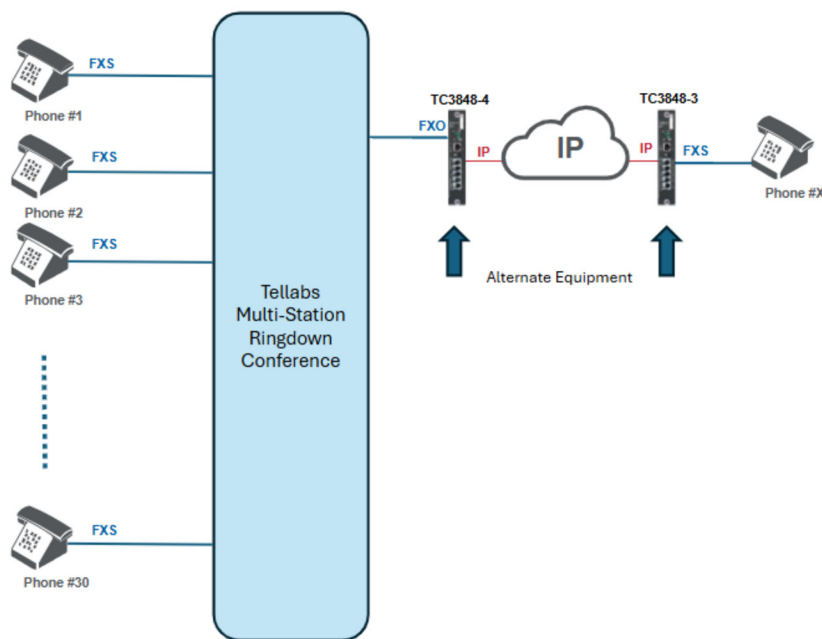

Final Design using TC3848-3/4

# Old Equipment; New Problem: Solving Legacy Device Issues for a Utility

## Take Two: Success

TC Communications promptly tested and configured new TC3848-3/4 cards and shipped them overnight in exchange for the original TC3848-1/2 cards.

A couple of days later, the IT lead on the project reported: “The TC3848-3/4 cards that I received today worked out great. I tested those out and they perform just as we need them!”

Although significant testing was required, the result was worth it: With the help of JumboSwitch products, the state Department of Transportation site had a scalable setup for phones that could accommodate phone conferencing.

“Thanks for your great support on this project!” the IT lead said. “You guys went above and beyond my expectations.”

## Where Preparation Meets Adaptability

TC Communications is committed to helping customers determine the best solutions for their applications, even when there is no obvious answer. When the company does not carry a product that fits a customer’s requirements, frequently, TC sales managers and engineers are able to deliver a solution with an existing or modified product by working closely with stakeholders.

In cases involving unfamiliar legacy products, or when little to no existing information is available, TC engineers step back, carefully analyze (and reanalyze) the customer’s system and technical requirements, and conduct testing until they reach an informed conclusion or solve the customer’s problem.



17881 Cartwright Road Irvine, CA 92614 | +1-949-852-1972 | [tccomm.com](http://tccomm.com)

Note: Information contained in this data sheet is subject to change without prior notice.  
LT0008-0603 ver01

