

TC8927

6+2-Ch. Paging System w/ Dry Contact

User Manual
MNL-89270-01-00



TC Communications, Inc. 17881 Cartwright Road - Irvine, CA 92614

Tel: (949) 852-1972 Fax: (949) 852-1948 Web Site: www.tccomm.com Email: sales@tccomm.com

All Rights Reserved

Copyright © 2019 by TC Communications. Products described in this publication are protected by one or more U.S. and foreign patents.

Trademarks

The TC Communications® logo is a registered trademark.

JumboSwitch® is a registered trademark of TC Communications.

Other product and brand names may be trademarks or registered trademarks of their respective owners.

Documentation Disclaimer

This document is provided “as-is” and is to be used only as a general guide. TC Communications disclaims all warranties, express or implied, regarding the accuracy of the information. TC Communications shall not be liable for any indirect, special, incidental, or consequential damages (including damages for loss of business, loss of profits, loss of business information, business interruption or other pecuniary loss) arising out of errors in this document.

The information given in this document is reviewed regularly and any necessary corrections will be included in subsequent editions. We appreciate any suggested improvements. We reserve the right to make technical improvements without notice.

Dissemination or reproduction of this document, or evaluation and communication of its contents, is not authorized except where expressly permitted. Violations are liable for damages. All rights reserved, particularly for the purposes of patent application or trademark registration. This document contains proprietary information, which is protected by copyright. All rights are reserved. No part of this document may be photocopied, reproduced or translated to another language without the prior written consent of TC Communications.

Record of Revisions

Revision	Date	Description of Changes
1.0	06/04/19	Initial Release of TC8927.

TC Communications
17881 Cartwright Road
Irvine, California U.S.A. 92614
Tel. (949) 852-1972
Fax (949) 852-1948
E-Mail: sales @tccomm.com
Website: tccomm.com

Guide to Alert Symbols

These alert symbols are used in Caution, Warning, and Danger notes.





Symbol	Meaning
	Pinching or crushing hazard
	Electrical hazard.
	Equipment alert: be careful of damage from static electricity
	General alert: used for all other hazardous conditions (referring to people, not equipment).

TABLE OF CONTENTS

1 Introduction

1.1	General Information	1-1
1.2	Product Description	1-1
1.2.1	Features	1-3
1.2.2	Applications.	1-4
1.3	Specifications	1-5

2 Installation

2.1	General Information	2-1
2.2	Unpacking	2-1
2.3	Equipment Location	2-1
2.4	Power Supply	2-2
2.5	Dry Contact Alarm Relay (DCAR)	2-2
2.6	System Start Up	2-2
2.7	System Configuration.	2-2
2.7.1	Front Panel (Analog Pin Assignments).	2-3
2.7.2	Rear Panel	2-3
2.7.3	Electrical Signal Interface Connection & Pin Assignments	2-6

5 Troubleshooting

5.1	General.	5-1
5.2	All LEDs are OFF	5-1
5.3	Alarm LED	5-1

Appendix A 19” Rack Mount Card Cage

A.1	Features	A-1
A.2	Description	A-1
A.3	Chassis Ground	A-1

Appendix B Return Policy

B.1	Return Policy	B-1
B.1.1	Warranty	B-1
B.1.2	Limitation of Liability	B-2

In this chapter:

- *Product Description*, on page 1-1
- *Specifications*, on page 1-5

1.1 General Information

This manual is intended to describe the features and functionality in addition to aiding in the planning, configuring, commissioning and maintaining of the TC8927 Paging System with Dry Contact.

1.2 Product Description

The TC8927 bridges/broadcasts analog audio and dry contact from a central location to remote sites. An incoming analog/dry contact signal coming into the primary host port will be broadcast to 6 slave ports. A backup host port is available for redundancy. The dry contact channel is typically used to actuate the end equipment to broadcast the audio. When both Primary and Backup host ports receive signal, Primary will take precedence.

Diagnostic LEDs are available to quickly identify issues with your analog lines.



Figure 1-1 TC8927 6+2 Channel Paging System with Dry Contact

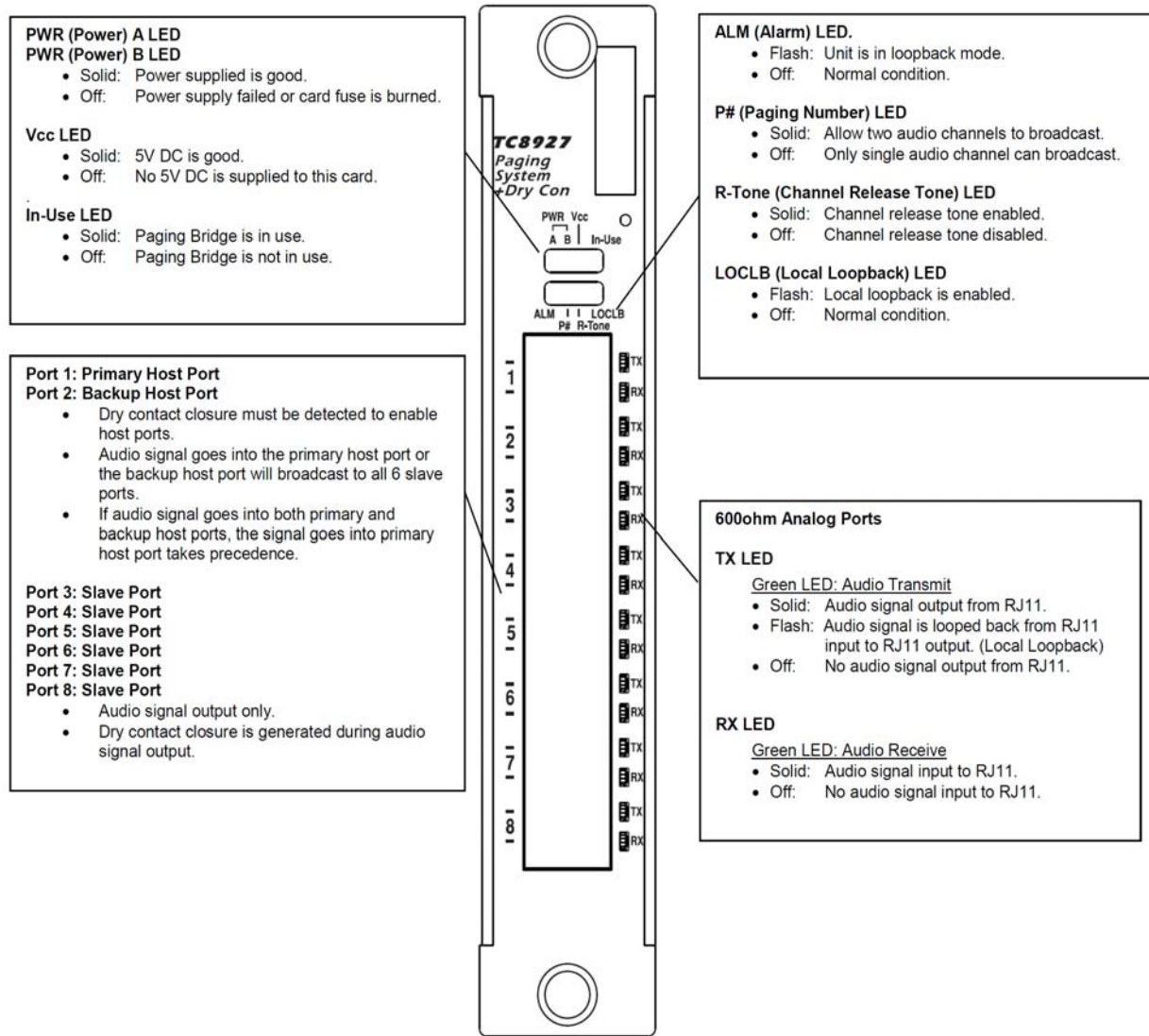

Figure 1-2 TC8927 Front Panel LED Definitions

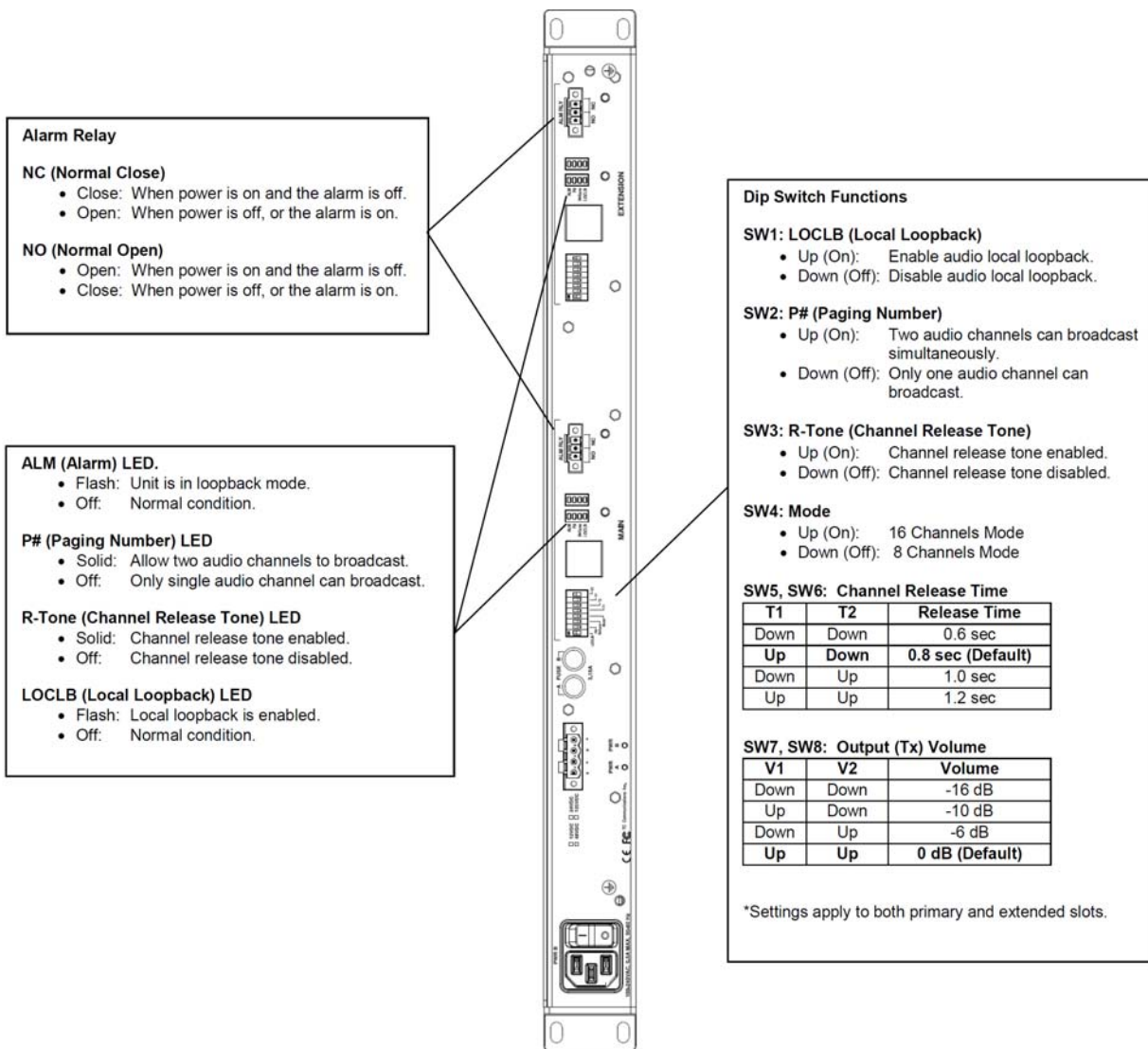

Figure 1-3 TC8927 Rear Panel LED Definitions

1.2.1 Features

- 2 Channel Inputs as Host Ports
- 6 Channel Outputs as Slave Ports
- Modular Design with 8 Channels per Module
- 64K Full Bandwidth Voice Transport
- Passes All Tones used for FSK, EIA Tone Control/Remote and Paging
- Supports Pilot/Guard Tone Operation
- Optional Power Redundancy
- 1U or 4U Rack Mount or 1S Standalone Chassis
- 12VDC, 24VDC, -48VDC, 125VDC

- LEDs for Analog Volume, Alarm Status, Channel Release Tone, and Loopback

1.2.2 Applications

The TC8927 bridges/broadcasts analog audio and dry contact from a central location to remote sites.

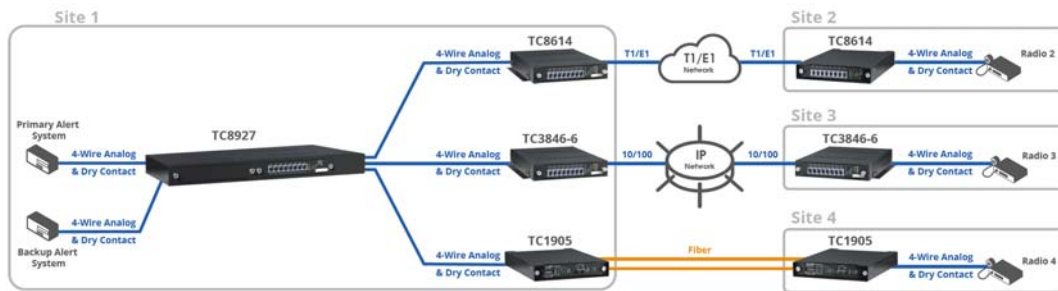

Figure 1-4 Typical Application using the TC8927

1.3 Specifications

Connection Capacity	
600Ω (4-Wire)	2 ports (Host), 6 ports (Slave)
Dry Contact	2 ports DCD (Host), 6 ports DCC (Slave)

Electrical	
Analog/Dry Contact Connector	RJ-11
Impedance	600Ω

System	
Visual Indicators	System: PWR A, PWR B, Vcc, ALM Paging: P#, R-Tone Channel Status: TX (1 each Ports 1-8) RX (1 each Ports 1-8)
Diagnostic Functions	Local Loopback

Power Source	
Standard	12VDC @500mA
Optional	24VDC, -48VDC, 125VDC, or 100/240VAC

Temperature	
Operating	-10°C to 50°C
(Optional Hi-Temp Version)	-20°C to 70°C
(Optional Extreme-Temp Version)	-40°C to 80°C
Storage	-40°C to 90°C
Humidity	95% non-condensing

Physical (Rack mount 1U “Pizza Box”)	
Height	(4.3 cm) 1.7"
Width	(48.3 cm) 19"
Depth	(26.7 cm) 10.5"

In this chapter:

- *Power Supply*, on page 2-2
- *System Configuration*, on page 2-2

2.1 General Information

The installation section describes how to:

- Unpack the unit
- Ensure an optimum site location
- Install the power supply and dry contact connection

2.2 Unpacking

Before unpacking any equipment:

- Inspect all shipping containers for evidence of external damage caused during transportation
- Inspect for damage after it is removed from the containers

IMPORTANT



Any claims concerning shipping damage should be made directly to the pertinent shipping agencies. Any discrepancies should be reported immediately to the Customer Service Department at TC Communications, Inc. at (949) 852-1973.

2.3 Equipment Location

The TC8927 should be located in an area that provides adequate light, work space and ventilation.

Important

Avoid locating it next to any equipment that may produce electrical interference or strong magnetic fields, such as elevator shafts or heavy duty power supplies.

As with any electronic equipment, keep the unit from excessive moisture, heat, vibration and freezing temperatures.

2.4 Power Supply

The TC8927 can be powered by external DC power. Available power options are 12 VDC, 24 VDC, -48 VDC, and 125 VDC. There are two terminal block connectors labeled "PWR A" and "PWR B" only one is required to power up the unit. Since each TC8927 card is equipped with a power redundancy capability, the power LEDs on the front panel will light according to which power jack (A or B) is connected. Both LEDs will light when power redundancy is utilized.

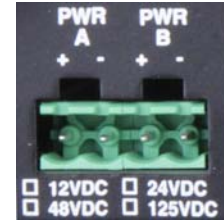

Important

Read and only connect a supply voltage that corresponds to the type plate of your device. Make sure that the contact load capacity of the signal contact is not exceeded.

2.5 Dry Contact Alarm Relay (DCAR)

A terminal block connector at the rear panel provides for the Dry Contact Alarm Relay. This relay can be used in NO (Normal Open) or NC (Normal Close) configuration.

When used in NO (Normal Open) configuration, the relay will close if the unit loses power completely or the Alarm is on. The relay remains open during normal operation.

When used in NC (Normal Close) configuration, the relay will open if the unit loses power completely or the Alarm is on. The relay remains close during normal operation.

2.6 System Start Up

Apply the power by plugging the power plug into a power jack (both PWR A & PWR B for dual power units).

After power is applied, all LEDs (except PWR & VCC LEDs) will flash momentarily and the following LED status should be observed from the front and back panels:

1. The Power "A" and/or "B" and VCC LEDs should be lit.

2.7 System Configuration

The TC8927 has been pre-tested and switches have been set per factory specifications.

2.7.1 Front Panel (Analog Pin Assignments)

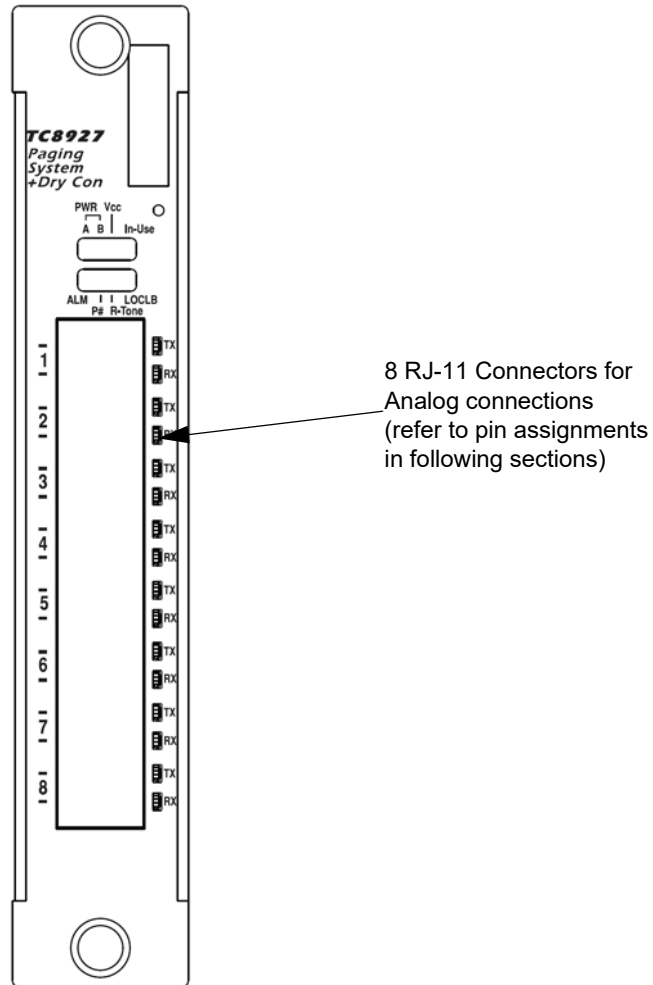

Figure 2-1 TC8927 Front Panel Analog & Dry Contact Connectors

2.7.2 Rear Panel

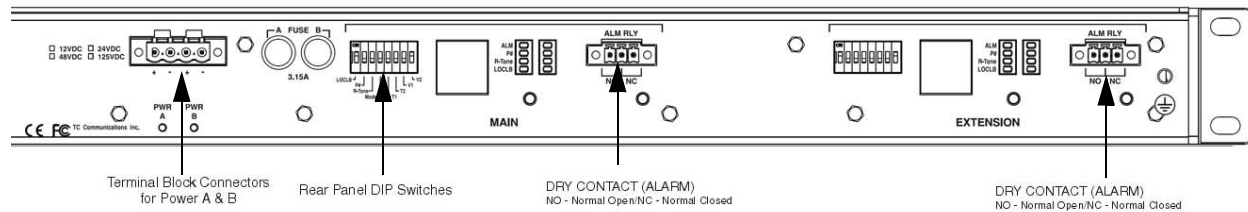
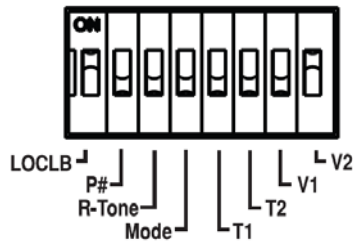

Figure 2-2 TC8927 Rear Panel (Main & Extension)

2.7.2.1 Rear Panel DIP Switch Functions



The DIP switch functions on the TC8927 are described below. To activate the function, set the appropriate switch to the “On” (Up) position.

- **LOCLB:** Local Loopback. This switch (SW1) initiates the Local Loopback function. The analog signals are received on the “RX Data” pins and looped back to the ”TX Data” pins for diagnostic testing.

Local Loopback Test (for 4-Wire analog only)

When the rear panel SW1 (LOCLB) in the “On”(Up) position the analog signals are received on the “Input” pins and looped back to the ”Output” pins on the TC8927.

1. The “TX” LED will be flashing green for that particular channel being tested and the "ALM" alarm LED will flash to indicate that the unit is in local loopback mode. (Note, the RX LED will be solidly lit green when an analog signal is detected.)
2. The Customer’s Analog Device should receive a 6dBm lower audio signal back as that of the transmitted signal.
3. Upon successful completion of this test, please return DIP switch SW1(LOCLB) to the “Off” (Down) position..

Local Loopback Test

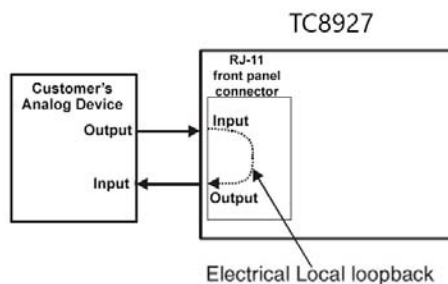

- **P#:** Paging Number. This switch (SW2) is used to enable the two channels broadcast function. "Off" (Down) for only allow single channel to broadcast. "On" (Up) allows two channels to broadcast simultaneously.

- **R-Tone:** Channel Release Tone. This switch (SW3) is used to enable the unit to generate a tone after a channel is release (Stop broadcasting). "Off" (Down) will disable the channel release tone. "On" (Up) will enable the channel release tone.
- **Mode:** 8/16 Channel Mode. This switch (SW4) is used to setup the number of Channels. "Off" (Down) is for 8 channels mode. "On" (Up) is for 16 channels mode.
- **T1, T2:** Channel Release Time. These switches are used to set the channel release time (stop broadcasting) after the channel stop receiving audio.

SW5, SW6: Channel Release Time		
T1	T2	Release Time
Down	Down	0.6 sec
Up	Down	0.8 sec (Default)
Down	Up	1.0 sec
Up	Up	1.2 sec

- **V1, V2:** Output (Tx) Volume. These switches are used to set the output volume for all the channels.

SW7, SW8: Output (Tx) Volume		
V1	V2	Volume
Down	Down	-16 dB
Up	Down	-10 dB
Down	Up	-6 dB
Up	Up	0 dB (Default)

2.7.3 Electrical Signal Interface Connection & Pin Assignments

The RJ-11 connectors are located at the front panel of the TC8927.

600Ω Analog Connections

RJ-11 600Ω Analog 4-Wire Port Pin Assignment (Host Ports)	
1	Detector Input
2	Output RING
3	Input RING
4	Input TIP
5	Output TIP
6	Detector Input (GND)

RJ-11 Jack

6 5 4 3 2 1

RJ-11 600Ω Analog 4-Wire Port Pin Assignment (Slave Ports)	
1	Relay Output
2	Output RING
3	Input RING
4	Input TIP
5	Output TIP
6	Relay Output

RJ-11 Jack

6 5 4 3 2 1

5.1 General

Under normal operation, PWR, and Vcc LEDs should be lit.

5.2 All LEDs are OFF

If no LEDs are lit on the unit, check the DC power supply, connector plug, and/or the power source. If the problem persists, contact the Technical Support Department at TC Communications, Inc. @ (949) 852-1973.

5.3 Alarm LED

Alarm conditions occur whenever local loopback is enabled and the ALARM LED will flash.

Appendix A 19" Rack Mount Card Cage

A.1 Features

- 1U height (1.75")
- Universal Power Supply Accepts 90V to 264V AC and 47 to 63 Hz AC
- Standard Power Supply is 12VDC, Optional 24VDC, -48VDC, 125VDC, or AC Power Supply Available
- Over Load & Short Circuit Protection

A.2 Description

This 1U "Pizza Box" Rack Mount Card Cages hold up to 2 single multiplexer type cards.

It operates with one power supply. The AC power supply automatically adjusts for 90V to 264V AC input and 47 to 63 Hz operation. The DC power supply accepts 24VDC, -48VDC, or 125VDC input (Optional).

This 1U rack assembly is 19" wide by 1.75" high, and is 9" deep.

A.3 Chassis Ground

The Stand alone and Rack mount chassis provide a connection point for chassis ground with a dedicated chassis ground screw and lock washer. The chassis ground screw is located on the rear side of the chassis. This chassis ground connection point is available in case chassis ground is taken into design consideration by the end user.

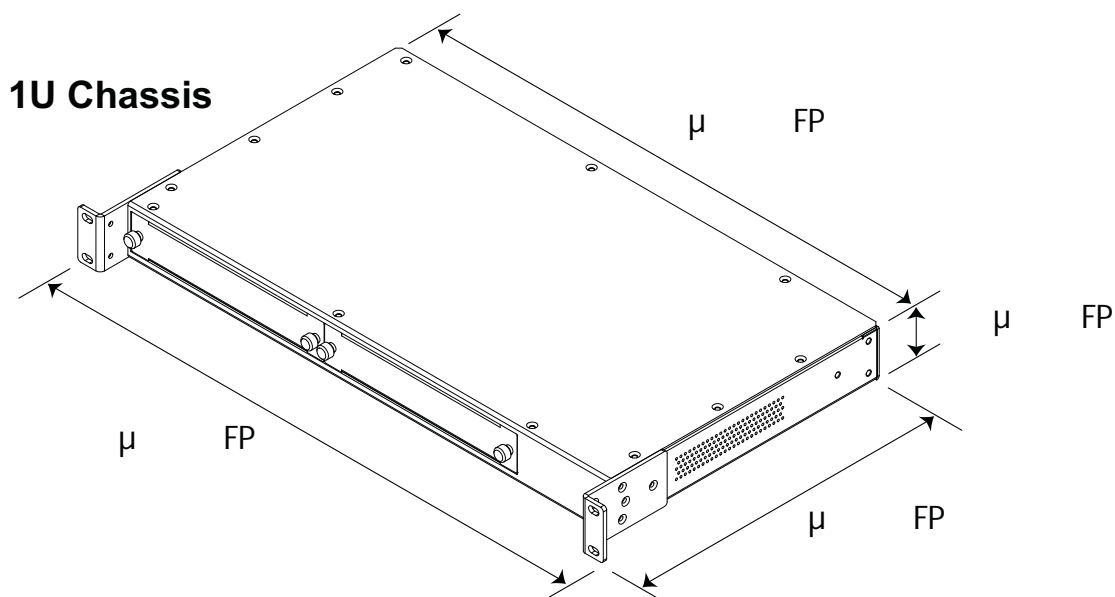

B.1 Return Policy

To return a product, you must first obtain a Return Material Authorization number from the Customer Service Department. If the product's warranty has expired, you will need to provide a purchase order to authorize the repair. When returning a product for a suspected failure, please provide a description of the problem and any results of diagnostic tests that have been conducted.

B.1.1 Warranty

Damages by lightning or power surges are not covered under this warranty.

All products manufactured by TC Communications, Inc. come with a five year (beginning 1-1-02) warranty. TC Communications, Inc. warrants to the Buyer that all goods sold will perform in accordance with the applicable data sheets, drawings or written specifications. It also warrants that, at the time of sale, the goods will be free from defects in material or workmanship. This warranty shall apply for a period of five years from the date of shipment, unless goods have been subject to misuse, neglect, altered or destroyed serial number labels, accidents (damages caused in whole or in part to accident, lightning, power surge, floods, fires, earthquakes, natural disasters, or Acts of God.), improper installation or maintenance, or alteration or repair by anyone other than Seller or its authorized representative.

Buyer should notify TC Communications, Inc. promptly in writing of any claim based upon warranty, and TC Communications, Inc., at its option, may first inspect such goods at the premises of the Buyer, or may give written authorization to Buyer to return the goods to TC Communications, Inc., transportation charges prepaid, for examination by TC Communications, Inc. Buyer shall bear the risk of loss until all goods authorized to be returned are delivered to TC Communications, Inc. TC Communications, Inc. shall not be liable for any inspection, packing or labor costs in connection with the return of goods.

In the event that TC Communications, Inc. breaches its obligation of warranty, the sole and exclusive remedy of the Buyer is limited to replacement, repair or credit of the purchase price, at TC Communications, Inc.'s option.

To return a product, you must first obtain a Return Material Authorization (RMA) number and RMA form from the Customer Service Department. If the product's warranty has expired, you will need to provide a purchase order to authorize the repair. When returning a product for a suspected failure, please fill out RMA form provided with a description of the problem(s) and any results of diagnostic tests that have been conducted. The shipping expense to TC Communications should be prepaid. The product should be properly packaged and insured. After the product is repaired, TC Communications will ship the product back to the shipper at TC's cost to U.S. domestic destinations. (Foreign customers are responsible for all shipping costs, duties and taxes [both ways]. We will reject any packages with airway bill indicating TC communications is responsible for Duties and Taxes. To avoid Customs Duties and Taxes, please include proper documents indicating the product(s) are returned for repair/retest).

B.1.2 Limitation of Liability

1. In no event shall the total liability of T C COMMUNICATIONS, INC. to purchaser and/or end user for all damages including but not limited to compensatory, consequential and punitive damages, exceed the total amount paid to T C Communications, Inc. by purchaser for the goods from which the claim arose, in no event shall T C COMMUNICATIONS, INC. be responsible for indirect and consequential damages.
2. In no event shall liability attached to T C COMMUNICATIONS, INC. unless notice in writing is given to T C COMMUNICATIONS, INC. within ten days of the occurrence of the event giving rise to such claim.
3. T C COMMUNICATIONS, INC. shall not be responsible for delays or non-deliveries directly or indirectly resulting from or contributed to by foreign or domestic embargoes, seizure, fire, flood, explosion, strike, act of God, vandalism, insurrection, riot, war, or the adoption or enactment of any law, ordinances, regulation, or ruling or order or any other cause beyond the control of T C COMMUNICATIONS, INC.
4. T C COMMUNICATIONS, INC. shall not be responsible for loss or damage in transit and any claims for such loss or damage shall be filed by the purchaser with the carrier.

Index

C

cabling, 2-2

D

DCAR, 2-2

E

electrical, 5-1

environmental
requirements, 2-1

F

front panel, 2-2

M

mechanical
installation, 2-2

P

power
unit, 2-2

S

specifications, 1-5

T

troubleshooting, 5-1

U

unpacking, 2-1

W

web
interface, 1-5