

TC3006

GIGABIT ETHERNET FIBER OPTIC MODE CONVERTER

User's Manual

MODEL: _____

S/N: _____

DATE: _____

Notice!

Although every effort has been made to insure that this manual is current and accurate as of date of publication, no guarantee is given or implied that this document is error free or accurate with regard to any specification. TC Communications, Inc. reserves the right to change or modify the contents of this manual at any time without prior notification.

© COPYRIGHT 1992-2009. ALL RIGHTS RESERVED.



TC Communications, Inc. 17881 Cartwright Road - Irvine, CA 92614
Tel: (949) 852-1972 Fax: (949) 852-1948 Web Site: www.tccomm.com Email: info@tccomm.com

Table Of Contents

Chapter 1 - Overview	3
Description	3
Data Rates	3
Optical Specifications	4
Transmission Distances (typical)	4
Launch Power & Sensitivity	4
Front Panel LEDs, DIP Switches, and Connectors	6
Rear Panel Connectors	6
Chapter 2 - Installation	7
Unpacking the Unit	7
Equipment Location	7
Power Supply	7
Dry Contact Alarm Relay	7
Installation Diagrams	8
Chapter 3 - Troubleshooting	9
Chapter 4 - Specifications	10
Appendix A	11
Return Policy	11
Warranty	11

Chapter 1 - Overview

Description

The TC3006 gives users the ability to convert Multimode fiber optic signals to Single Mode format for data transmission (and vice-versa). These conversions can benefit users by extending transmission distances and/or enabling dissimilar fiber optic devices to be used with different fiber types. The optic receiver detects the incoming optical signal and regenerates it for transmission through the second optic transmitter. The TC3006 is available in multiple configurations depending on your communication requirements. When both sides have the same wavelength, the TC3006 works like an optical signal repeater.

Data Rates

1000Mbps

Optical Specifications

Multimode 850nm, 275/550 Meter Option

Transmitter:	FP LASER; typical Launch Power:	-10.0 dBm @850nm
Receiver:	PIN Diode; typical Sensitivity: Optic saturation level:	-18.0 dBm @850nm 0 dBm @850nm
Loss Budget:	Multimode (50/125 μ m)@850nm: Multimode (62.5/125 μ m)@850nm:	8 dB 8 dB
Distance:	Multimode (50/125 μ m)@850nm: Multimode (62.5/125 μ m)@850nm:	up to 550 Meter distance* up to 275 Meter distance*
Wavelength:	Multimode 850nm:	
Connector*:	ST FC SC	

Multimode 1310nm, 2km Option

Transmitter:	FP LASER; typical Launch Power:	-6.0 dBm @1310nm
Receiver:	PIN Diode; typical Sensitivity: Optic saturation level:	-16.0 dBm @1310nm 0 dBm @1310nm
Loss Budget:	Multimode (50 or 62.5/125 μ m)@1310nm:	10 dB
Distance:	Multimode (50 or 62.5/125 μ m)@1310nm:	up to 2km distance*
Wavelength:	Multimode 1310nm:	
Connector*:	ST FC SC	

Single Mode 1310nm, 20km Option

Transmitter:	FP Laser; typical Launch Power:	-10 dBm @1310nm
Receiver:	PIN Diode; typical Sensitivity: Optic saturation level:	-20.0 dBm @1310nm -3 dBm @1310nm
Loss Budget:	Single Mode (9/125 μ m)@1310nm:	10 dB
Distance:	Single Mode (9/125 μ m)@1310nm:	up to 20 km distance*
Wavelength:	Single Mode 1310nm (LASER):	
Connector*:	ST FC SC	

Single Mode 1550nm, 50km Option

Transmitter:	FP Laser; typical Launch Power:	-4dBm @1310nm
Receiver:	PIN Diode; typical Sensitivity: Optic saturation level:	-23.0 dBm @1310nm -3 dBm @1310nm
Loss Budget:	Single Mode (9/125 μ m)@1310nm:	19dB
Distance:	Single Mode (9/125 μ m)@1310nm:	up to 50km distance*
Wavelength:	Single Mode 1310nm (LASER)	
Connector*:	ST FC SC	

**Launch power, sensitivity and distance are listed for reference only. These numbers may vary. Contact factory for higher loss budgets and ST & FC fiber connector types (SC fiber connectors are standard).*

Single Mode 1550nm, 80km Option

Transmitter:	Typical Launch Power:	0 dBm @1550nm
Receiver:	PIN Diode; typical Sensitivity: Optic saturation level:	-24.0 dBm @1550nm 0 dBm @1550nm
Loss Budget:	Single Mode (9/125µm)@1550nm:	24 dB
Distance:	Single Mode (9/125µm)@1550nm:	up to 80km distance*
Wavelength:	Single Mode 1550nm :	
Connector*:	ST FC SC	

Single Mode 1550nm, 120km Option

Transmitter:	DFB Laser; typical Launch Power:	0dBm @1550nm
Receiver:	PIN Diode; typical Sensitivity: Optic saturation level:	-32.0 dBm @1550nm -9dBm @1550nm
Loss Budget:	Single Mode (9/125µm)@1550nm:	32dB
Distance:	Single Mode (9/125µm)@1550nm:	up to 120km distance*
Wavelength:	Single Mode 1550nm (LASER)	
Connector*:	ST FC SC	

Single (One) Fiber, 40km Model

Transmitter:	Typical Launch Power	-3 to + 2 dBm* (1310nm/1550nm, @9/125µm)
Receiver:	PIN Diode; typical Sensitivity Optic saturation level	-23 dBm* (1310nm/1550nm, @9/125µm) -3 dBm*
Loss Budget:	1310nm/1550nm Single Mode, @9/125µm	20 dB
Distance:	1310nm/1550nm Single Mode, @9/125µm	up to 40km distance*
Wavelength:	1310nm/1550nm Single Mode	
Connector:	SC	Only*

**Launch power, sensitivity and distance are listed for reference only. These numbers may vary. Contact factory for higher loss budgets and ST & FC fiber connector types (SC fiber connectors are standard).*

Front Panel LEDs, DIP Switches and Connectors

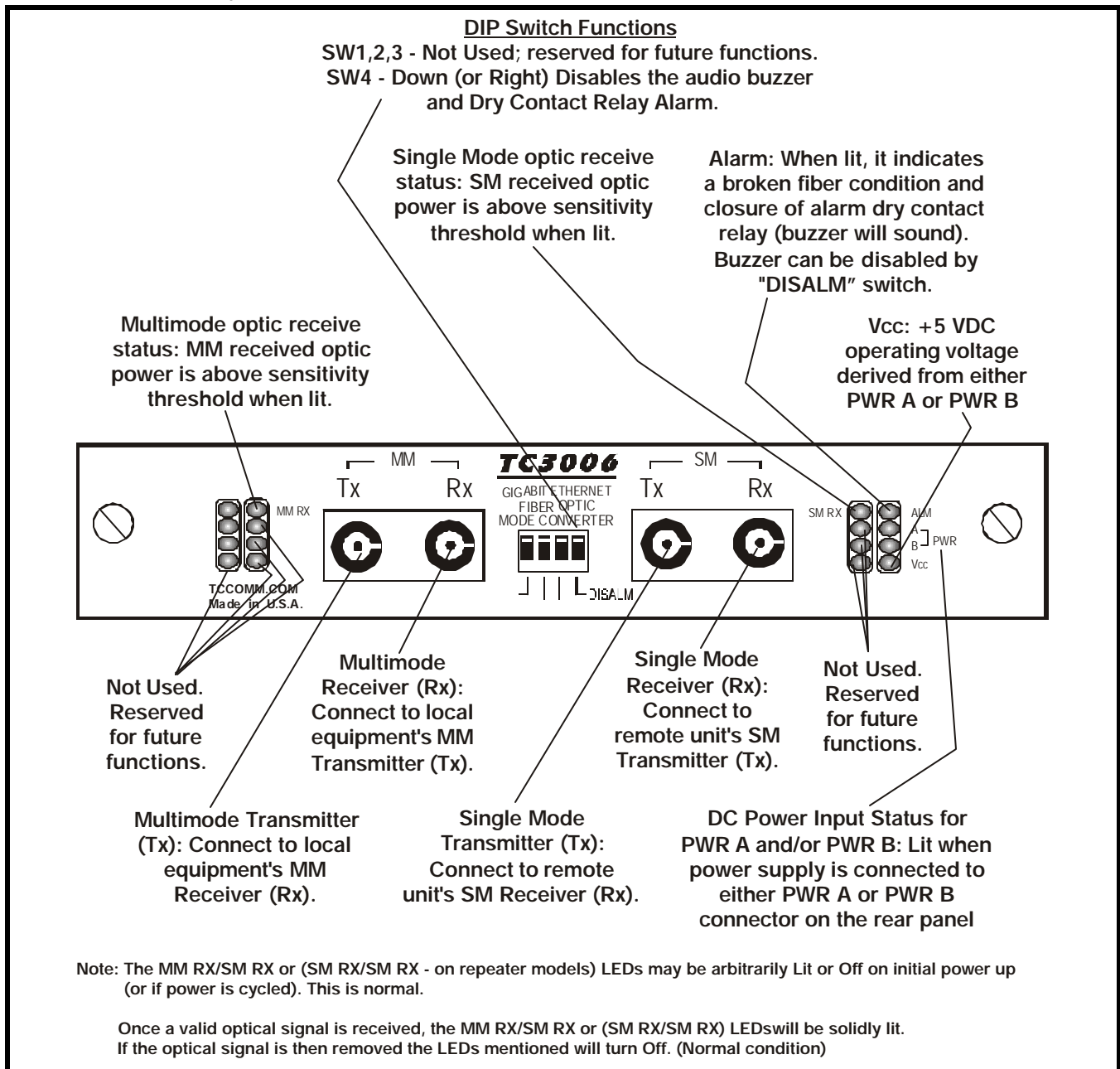

Figure 1. TC3006's Front Panel

Rear Panel Connectors

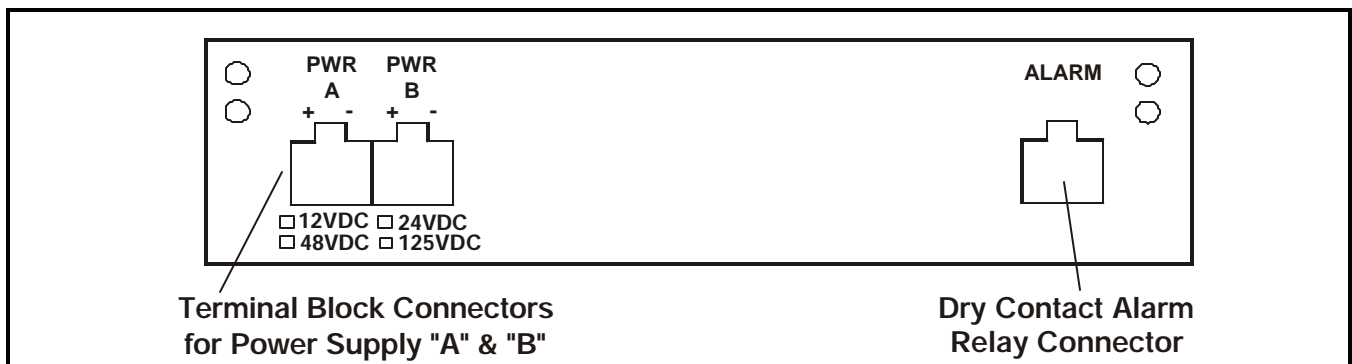

Figure 2. TC3006's Rear Panel

Chapter 2 - Installation

Unpacking the Unit

Before unpacking any equipment, inspect all shipping containers for evidence of external damage caused during transportation. The equipment should also be inspected for damage after it is removed from the container(s). Claims concerning shipping damage should be made directly to the pertinent shipping agencies. Any discrepancies should be reported immediately to the Customer Service Department at TC Communications, Inc.

Equipment Location

The TC3006 should be located in an area that provides adequate light, work space, and ventilation. Avoid locating it next to any equipment that may produce electrical interference or strong magnetic fields, such as elevator shafts or heavy duty power supplies. As with any electronic equipment, keep the unit from excessive moisture, heat, vibration, and freezing temperatures.

Power Supply

Standard input power to the TC3006 is 12VDC @600mA. There are two pairs of terminal block connectors on the rear panel (labeled "PWR A" and "PWR B"). Only one pair is required to power the unit. Polarity is indicated on each connector block. If both pairs are connected, the built-in power redundancy feature will be utilized. When this feature is utilized, both "A" and "B" share the load. If one power source fails, the other will assume the full load. Polarity is indicated on each connector block. Alternate power sources are available as an option (see Chapter 4 - Specifications).

Dry Contact Relay Alarm

A terminal block connector on the rear panel (labeled "ALARM") provides for the dry contact relay alarm (see Figure 2). Normally in the OPEN position, the loss of either optic signal will trigger an alarm condition and force the switch to the CLOSED position. This relay can be used in conjunction with an external device to monitor the condition of the fiber optic links. Note: If SW4 (DISALM) on the front panel is in the Down position, the audio buzzer will not sound and the dry contact relay will not activate.

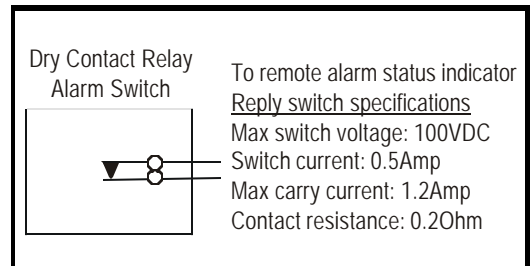

Installation Diagrams

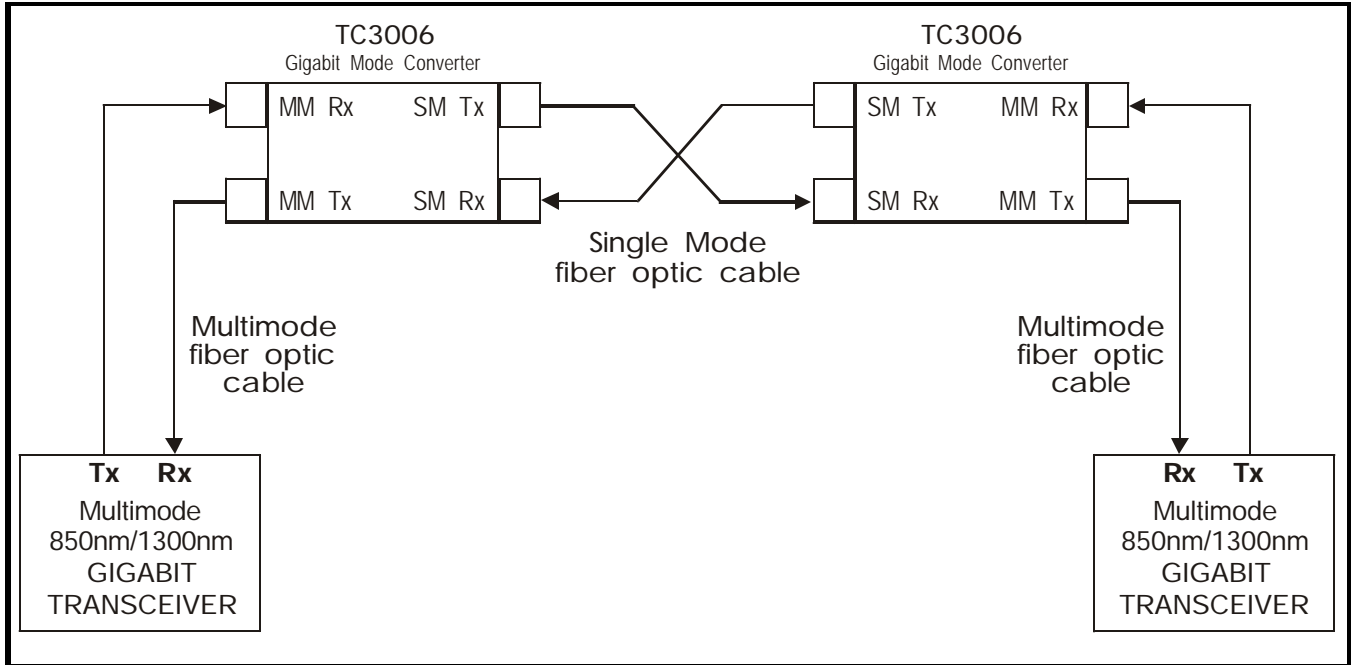

Figure 3. Installation Diagram for Dual TC3006 Application

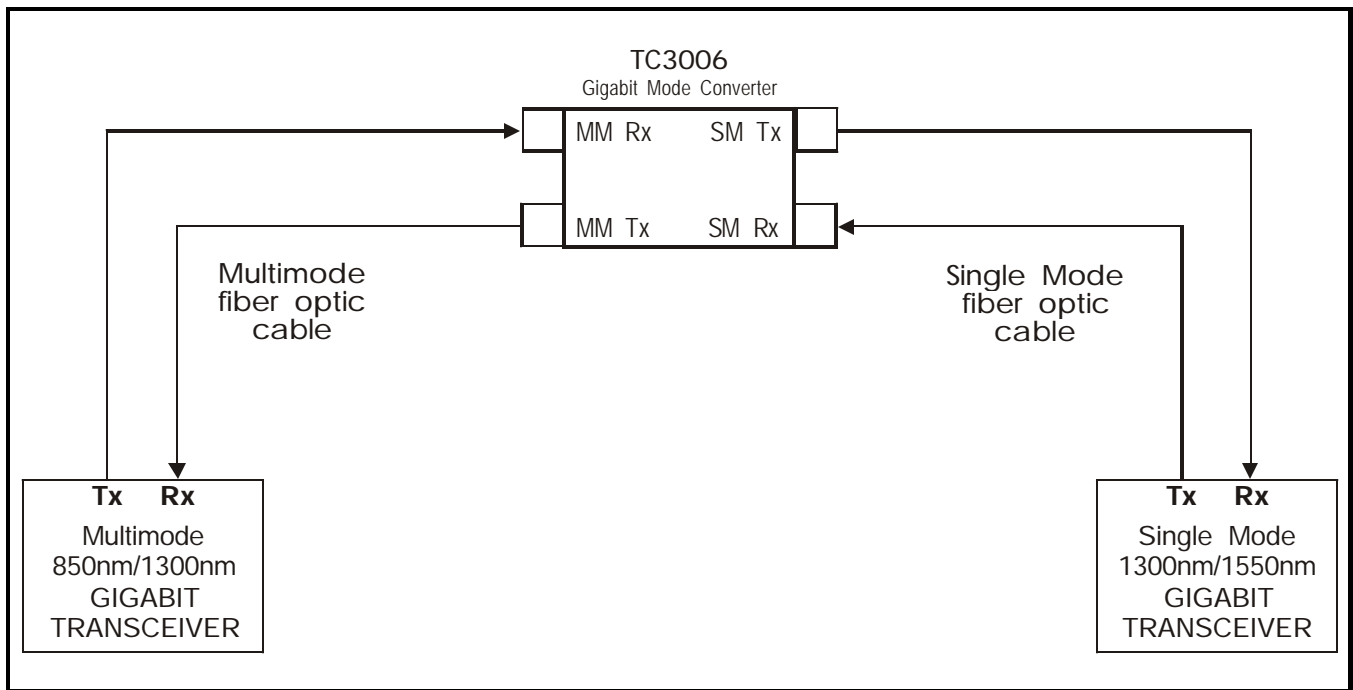

Figure 4. Installation Diagram for Single TC3006 Application

Chapter 3 - Troubleshooting

Typically, most problems encountered with the TC3006 are related to optic receiver overdrive. The maximum optic power that can be received without distortion is referred to as the optic receiver's "saturation level." When the incoming optic power is greater than the saturation level of the receiver, optic "overdrive" can occur.

For example, the TC3006's (Single Mode 1310nm, 20km model) optic receivers have a typical saturation level of -3dBm. If the user's equipment's launch power is higher than -3dBm (i.e. -2dBm or greater) and the fiber run is very short and has low signal loss, it is likely to overdrive the TC3006's Multimode receiver. The consequences of overdrive can be high error rates or the device's failure to recognize the incoming optic signal at all.

The TC3006 has been adjusted at the factory so that the Single Mode transmitter will not overdrive the Single Mode receiver even when short cables are used to connect them; hence, the overdrive condition happens most frequently at the Multimode receiver optic.

If you suspect the Multimode receiver has an optic overdrive condition, a simple test will help verify it. At the receiving optic in question, simply disconnect the optic connector and back it out of the receptacle (about 1/8 of an inch), creating a gap between the fiber connector and the receiver. Verify that the equipment is still in "sync" with the optic signal and that the overdrive condition has been corrected. To resolve the overdrive condition permanently, insert a 5dB or 10dB in-line attenuator into the problem link. In-line attenuators can be purchased from Metrotek* at (727) 547-8307. The part numbers are:

Description:	ST@5dB	ST@10dB	FC@5dB	FC@10dB
Part Number:	68-JJ-7-0513	68-JJ-7-1013	68-FF-0513	68-FF-1013

The following diagram illustrates a TC3006 Mode Converter used to convert a 1310nm Single Mode optical signal from a Gigabit Switch #1 into an 850nm Multimode optical signal to be received by a second Gigabit Switch #2. In the reverse direction, the Gigabit Switch #2's Multimode optical signal is converted to Single Mode format to be received by the Gigabit Switch #1. In-line attenuators are used to correct optic overdrive conditions that exist on either side of the TC3006.

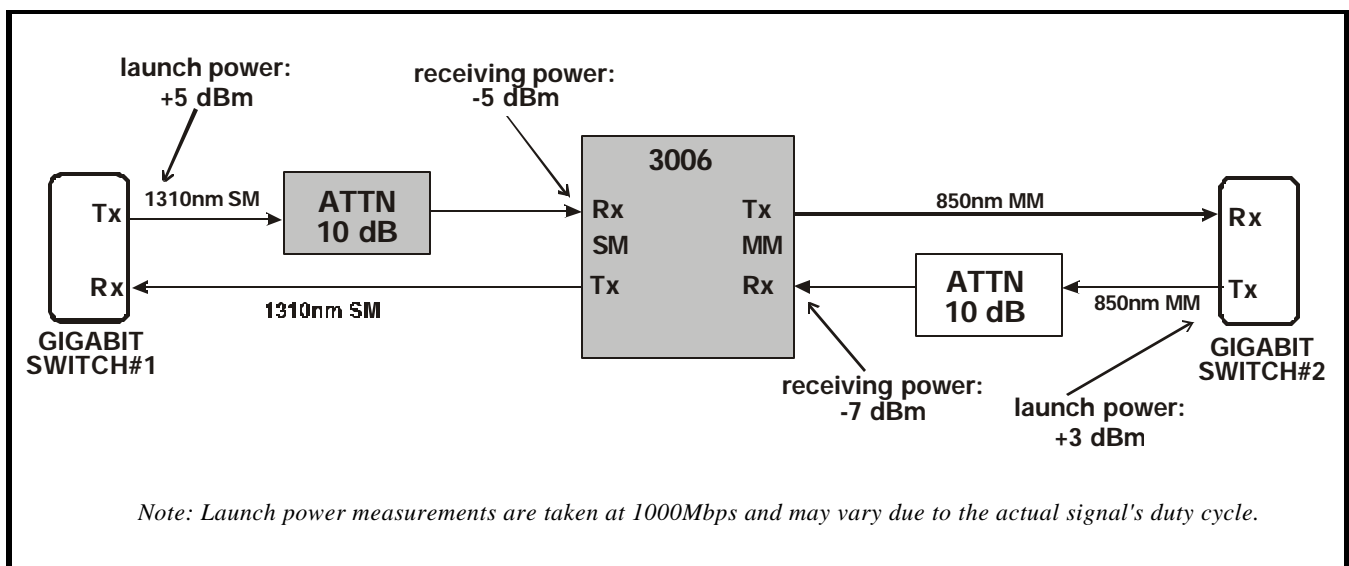

Figure 5. In-line Attenuator Placement Diagram

Chapter 4 - Specifications

Data Rates

..... 1000Mbps

Optical

See pages 4 and 5

Indicators

System statusALARM, PWR A, PWR B, Vcc
Optic Signal Status MM RX, SM RX

Power Source

Standard 12VDC @600mA (typical)
Optional 24VDC, 48VDC, 125VDC, or 115/230VAC with an external power cube

Temperature

Operating -10°C to 50°C
..... Hi-Temp Version (Optional) -20°C to 70°C
Storage -40°C to 90°C
Humidity 95% non-condensing

Physical Characteristics

Rack Mountable Card

Height: 7.0" (17.7 cm)
Width: 1.2" (3.1 cm)
Depth: 5.8" (14.8 cm)
Weight: 8.5 oz. (188 gm)

Stand Alone Unit

Height: 1.4" (3.5 cm)
Width: 7.1" (18 cm)
Depth: 6.6" (16.6 cm)
Weight: 1.5 lbs. (512 gm)

Appendix A

Return Policy

To return a product, you must first obtain a Return Material Authorization number from the Customer Service Department. If the product's warranty has expired, you will need to provide a purchase order to authorize the repair. When returning a product for a suspected failure, please provide a description of the problem and any results of diagnostic tests that have been conducted.

Warranty

Damages by lightning or power surges are not covered under this warranty.

All products manufactured by TC Communications, Inc. come with a five year (beginning 1-1-02) warranty. TC Communications, Inc. warrants to the Buyer that all goods sold will perform in accordance with the applicable data sheets, drawings or written specifications. It also warrants that, at the time of sale, the goods will be free from defects in material or workmanship. This warranty shall apply for a period of five years from the date of shipment, unless goods have been subject to misuse, neglect, altered or destroyed serial number labels, accidents (damages caused in whole or in part to accident, lightning, power surge, floods, fires, earthquakes, natural disasters, or Acts of God.), improper installation or maintenance, or alteration or repair by anyone other than Seller or its authorized representative.

Buyer should notify TC Communications, Inc. promptly in writing of any claim based upon warranty, and TC Communications, Inc., at its option, may first inspect such goods at the premises of the Buyer, or may give written authorization to Buyer to return the goods to TC Communications, Inc., transportation charges prepaid, for examination by TC Communications, Inc. Buyer shall bear the risk of loss until all goods authorized to be returned are delivered to TC Communications, Inc. TC Communications, Inc. shall not be liable for any inspection, packing or labor costs in connection with the return of goods.

In the event that TC Communications, Inc. breaches its obligation of warranty, the sole and exclusive remedy of the Buyer is limited to replacement, repair or credit of the purchase price, at TC Communications, Inc.'s option.

To return a product, you must first obtain a Return Material Authorization (RMA) number and RMA form from the Customer Service Department. If the product's warranty has expired, you will need to provide a purchase order to authorize the repair. When returning a product for a suspected failure, please fill out RMA form provided with a description of the problem(s) and any results of diagnostic tests that have been conducted. The shipping expense to TC Communications should be prepaid. The product should be properly packaged and insured. After the product is repaired, TC Communications will ship the product back to the shipper at TC's cost to U.S. domestic destinations. (Foreign customers are responsible for all shipping costs, duties and taxes [both ways]. We will reject any packages with airway bill indicating TC communications is responsible for Duties and Taxes. To avoid Customs Duties and Taxes, please include proper documents indicating the product(s) are returned for repair/retest).