

TC3025

FIBER OPTIC MODE CONVERTER/REPEATER FOR C37.94

User's Manual

MODEL: _____

S/N: _____

DATE: _____

Notice!

Although every effort has been made to insure that this manual is current and accurate as of date of publication, no guarantee is given or implied that this document is error free or accurate with regard to any specification. TC Communications, Inc. reserves the right to change or modify the contents of this manual at any time without prior notification.

© COPYRIGHT 1992-2019. ALL RIGHTS RESERVED.



TC Communications, Inc. 17881 Cartwright Road - Irvine, CA 92614

Tel: (949) 852-1972 Fax: (949) 852-1948 Web Site: www.tccomm.com Email: info@tccomm.com

MNL-30250-02-07

Table Of Contents

TC3025 (LASER)
User's Manual
Rev. 2.7

Chapter 1 - Overview	3
Description	3
Data Rates	3
Optical Specifications	3
Transmission Distances (typical)	3
Launch Power & Sensitivity	3
Front Panel LEDs, DIP Switches, and Connectors	4
Rear Panel Connectors	4
Chapter 2 - Installation	5
Unpacking the Unit	5
Equipment Location	5
Power Supply	5
Dry Contact Alarm Relay	5
Installation Diagram	6
Chapter 3 - Troubleshooting	7
Chapter 4 - Specifications	8
Appendix A	9
Return Policy	9
Warranty	9
Limitation of Liability	9

Record of Revisions

Revision	Date	Description of Changes
2.7	02/07/2019	Dry Contact Relay Alarm enhancement/modification. Optical specifications modification.

Description

The TC3025 gives users the ability to convert Multimode fiber optic signals to Single Mode format for data transmission (and vice-versa) for C37.94 teleprotection relays. These conversions can benefit users by extending transmission distances and/or enabling dissimilar fiber optic devices to be used with different fiber types. The optic receiver detects the incoming optical signal and regenerates it for transmission through the second optic transmitter. The TC3025 is available in multiple configurations depending on your communication requirements. When both sides have the same wavelength, the TC3025 works like an optical signal repeater.

Data Rates

IEEE C37.94

Optical Specifications

Transmitter:	LASER (FP); typical Launch Power: -23 to -11 dBm* (850nm, Multimode @62.5/125 μ m) - 8 to - 2 dBm* (1310nm, Single Mode @9/125 μ m) LASER (DBF); typical Launch Power: - 1 to +5 dBm* (1550nm, Single Mode @9/125 μ m)
Receiver:	PIN DIODE; typical Sensitivity: < -32 dBm* (850nm, Multimode @62.5/125 μ m) < -36 dBm* (1310nm, Single Mode @9/125 μ m) < -36 dBm* (1550nm, Single Mode @9/125 μ m)
Loss Budget:	850nm, MM @62.5/125 μ m 13 dB LASER (FP) 850nm, MM @50/125 μ m 9 dB LASER (FP) 1310nm, SM @9/125 μ m 28 dB LASER (FP) 1550nm, SM @9/125 μ m 36 dB LASER (DBF)
Distance:	850nm, Multimode @62.5/125 μ m up to 2km* 1310nm, Single Mode @9/125 μ m up to 60km* 1550nm, Single Mode @9/125 μ m up to 100km*
Wavelength:	Note: Any two wavelength combinations are available on each unit. 850nm or 1310nm Multimode 1310nm or 1550nm Single Mode
Connector:	ST for both MM or SM. Check with factory on SC, FC availability.

*Launch power, sensitivity and distance are listed for reference only. These numbers may vary.

Front Panel LEDs, DIP Switches and Connectors

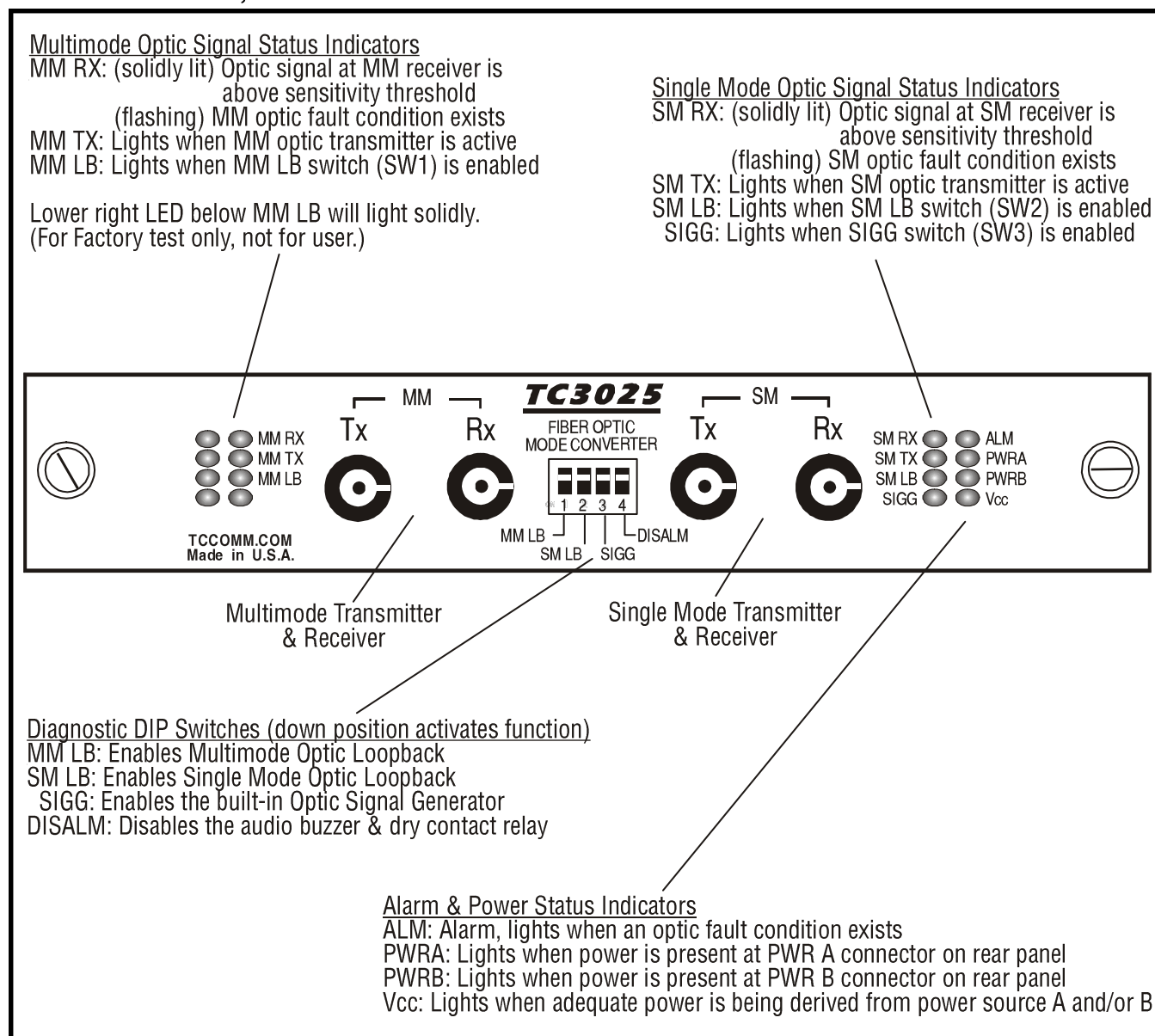

Figure 1. TC3025's Front Panel

Rear Panel Connectors

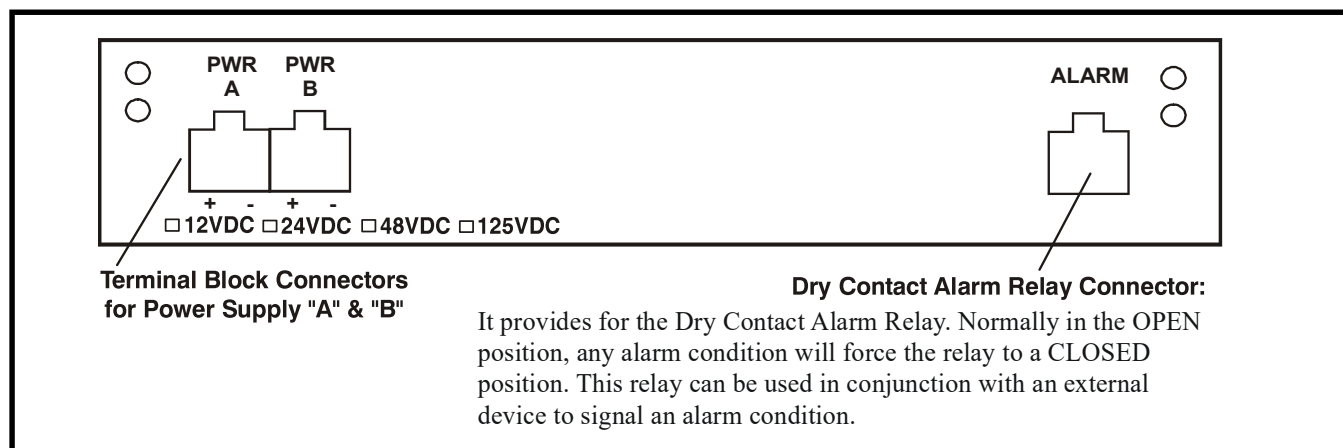

Figure 2. TC3025's Rear Panel

Unpacking the Unit

Before unpacking any equipment, inspect all shipping containers for evidence of external damage caused during transportation. The equipment should also be inspected for damage after it is removed from the container(s). Claims concerning shipping damage should be made directly to the pertinent shipping agencies. Any discrepancies should be reported immediately to the Customer Service Department at TC Communications, Inc.

Equipment Location

The TC3025 should be located in an area that provides adequate light, work space, and ventilation. Avoid locating it next to any equipment that may produce electrical interference or strong magnetic fields, such as elevator shafts or heavy duty power supplies. As with any electronic equipment, keep the unit from excessive moisture, heat, vibration, and freezing temperatures.

Power Supply

Standard input power to the TC3025 is 12VDC @800mA. There are two pairs of terminal block connectors on the rear panel (labeled "PWR A" and "PWR B"). Only one pair is required to power the unit. Polarity is indicated on each connector block. If both pairs are connected, the built-in power redundancy feature will be utilized. When this feature is utilized, both "A" and "B" share the load. If one power source fails, the other will assume the full load. Polarity is indicated on each connector block. Alternate power sources are available as an option (see Chapter 4 - Specifications).

Dry Contact Relay Alarm

A terminal block connector on the rear panel (labeled "ALARM") provides for the dry contact relay alarm (see Figure 2). Normally in the OPEN position, the loss of either fiber optic signal or power will trigger an alarm condition and force the switch to the CLOSED position. This relay can be used in conjunction with an external device to monitor the condition of the fiber optic links. Note: If SW4 (DISALM) on the front panel is in the Down position, the on-board audio buzzer will not sound and the dry contact relay will not activate.

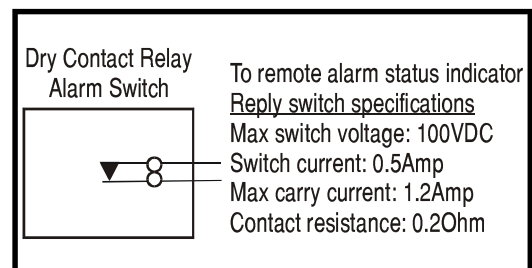

Note: Dry Contact Alarm Relay (DCAR) can be ordered in Normal Closed configuration. Please contact the factory prior to purchasing.

When used in NC (Normal Close) configuration, the relay will OPEN if the unit loses power completely or the alarm is triggered by the loss of either fiber optic signal. If fiber optic signal is lost, the alarm "ALM" LED will be lit and the on-board audio buzzer will be on. The relay remains CLOSED during normal operation.

Installation Diagram

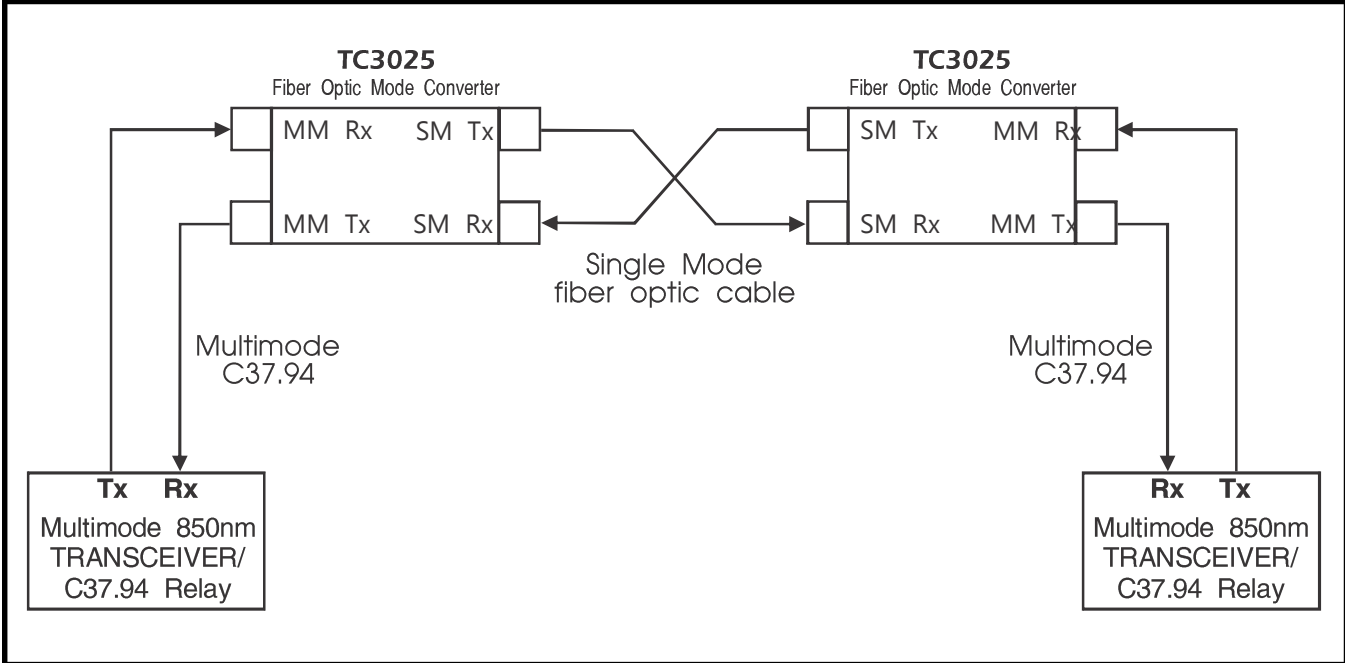

Figure 3. Installation Diagram for Dual TC3025 Application

Typically, most problems encountered with the TC3025 are related to optic receiver overdrive. The maximum optic power that can be received without distortion is referred to as the optic receiver's "saturation level." When the incoming optic power is greater than the saturation level of the receiver, optic "overdrive" can occur.

The TC3025's optic receivers have a typical saturation level of -3 dBm. If the user's equipment's launch power is higher than -3 dBm (i.e. -2 dBm or greater) and the fiber run is very short and has low signal loss, it is likely to overdrive the TC3025's Multimode receiver. The consequences of overdrive can be high error rates or the device's failure to recognize the incoming optic signal at all.

The TC3025 has been adjusted at the factory so that the Single Mode transmitter will not overdrive the Single Mode receiver even when short cables are used to connect them; hence, the overdrive condition happens most frequently at the Multimode receiver optic.

If you suspect the Multimode receiver has an optic overdrive condition, a simple test will help verify it. At the receiving optic in question, simply disconnect the optic connector and back it out of the receptacle (about 1/8 of an inch), creating a gap between the fiber connector and the receiver. Verify that the equipment is still in "sync" with the optic signal and that the overdrive condition has been corrected. To resolve the overdrive condition permanently, insert a 5dB or 10dB in-line attenuator into the problem link. In-line attenuators can be purchased from Metrotek* at (727) 547-8307. The part numbers are:

Description:	ST@5dB	ST@10dB
Part Number:	68-JJ-7-0513	68-JJ-7-1013

In-line attenuators are used to correct optic overdrive conditions that may exist on either side of the TC3025s.

The following is a typical diagram illustrating a TC3025 Mode Converter used to convert a 1300nm Single Mode optical signal from a Single Mode Device into a 850nm Multimode optic signal to be received by a Multimode Device.

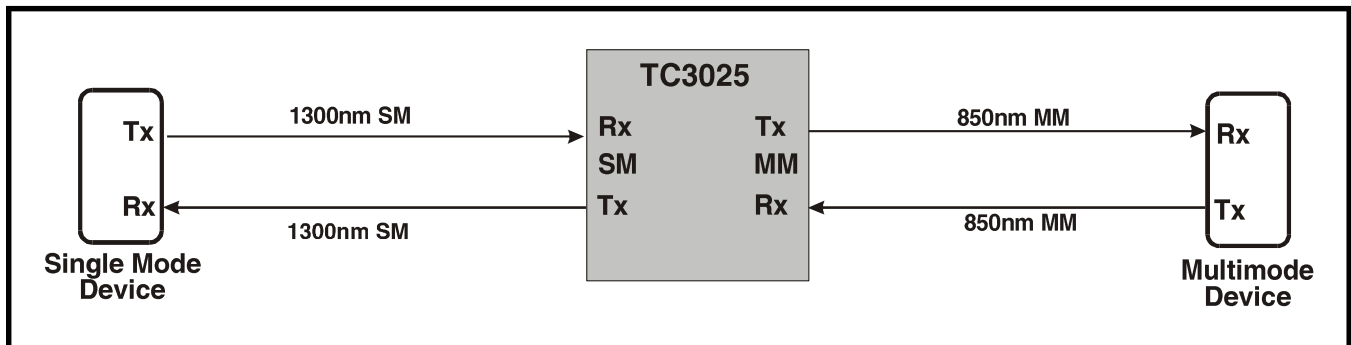

Figure 4. Typical Single Mode to Multimode Conversion Diagram

Data Rates

..... IEEE C37.94

Optical

See page 3

Indicators

System statusPWRA, PWRB, ALM, Vcc
Optic Signal Status MM Rx, MM Tx, SM Rx, SM Tx
Diagnostic Status MM LB, SM LB, SIGG

Power Source

Standard 12VDC @800mA (typical)
Optional 24VDC or -48VDC

Temperature

Operating -10°C to 50°C
..... Hi-Temp Version (Optional) -20°C to 70°C
..... Extreme Temp Version (Optional) -40°C to 80°C
Storage -40°C to 90°C
Humidity 95% non-condensing

Physical Characteristics

Rack Mountable Card

Height: 7.0" (17.7 cm)
Width: 1.2" (3.1 cm)
Depth: 5.8" (14.8 cm)
Weight: 8.5 oz. (188 gm)

Stand Alone Unit

Height: 1.4" (3.5 cm)
Width: 7.1" (18 cm)
Depth: 6.6" (16.6 cm)
Weight: 1.5 lbs. (512 gm)

*Consult factory for higher requirements .

Return Policy

To return a product, you must first obtain a Return Material Authorization number from the Customer Service Department. If the product's warranty has expired, you will need to provide a purchase order to authorize the repair. When returning a product for a suspected failure, please provide a description of the problem and any results of diagnostic tests that have been conducted.

Warranty

Damages by lightning or power surges are not covered under this warranty.

All products manufactured by TC Communications, Inc. come with a five year (beginning 1-1-02) warranty. TC Communications, Inc. warrants to the Buyer that all goods sold will perform in accordance with the applicable data sheets, drawings or written specifications. It also warrants that, at the time of sale, the goods will be free from defects in material or workmanship. This warranty shall apply for a period of five years from the date of shipment, unless goods have been subject to misuse, neglect, altered or destroyed serial number labels, accidents (damages caused in whole or in part to accident, lightning, power surge, floods, fires, earthquakes, natural disasters, or Acts of God.), improper installation or maintenance, or alteration or repair by anyone other than Seller or its authorized representative.

Buyer should notify TC Communications, Inc. promptly in writing of any claim based upon warranty, and TC Communications, Inc., at its option, may first inspect such goods at the premises of the Buyer, or may give written authorization to Buyer to return the goods to TC Communications, Inc., transportation charges prepaid, for examination by TC Communications, Inc. Buyer shall bear the risk of loss until all goods authorized to be returned are delivered to TC Communications, Inc. TC Communications, Inc. shall not be liable for any inspection, packing or labor costs in connection with the return of goods.

In the event that TC Communications, Inc. breaches its obligation of warranty, the sole and exclusive remedy of the Buyer is limited to replacement, repair or credit of the purchase price, at TC Communications, Inc.'s option.

To return a product, you must first obtain a Return Material Authorization (RMA) number and RMA form from the Customer Service Department. If the product's warranty has expired, you will need to provide a purchase order to authorize the repair. When returning a product for a suspected failure, please fill out RMA form provided with a description of the problem(s) and any results of diagnostic tests that have been conducted. The shipping expense to TC Communications should be prepaid. The product should be properly packaged and insured. After the product is repaired, TC Communications will ship the product back to the shipper at TC's cost to U.S. domestic destinations. (Foreign customers are responsible for all shipping costs, duties and taxes [both ways]. We will reject any packages with airway bill indicating TC communications is responsible for Duties and Taxes. To avoid Customs Duties and Taxes, please include proper documents indicating the product(s) are returned for repair/retest).

Limitation of Liability

In no event shall the total liability of TC Communications, Inc. to purchaser and/or end user for all damages including but not limited to compensatory, consequential and punitive damages, exceed the total amount paid to TC Communications, Inc. by purchaser for the goods from which the claim arose, in no event shall TC Communications, Inc. be responsible for indirect and consequential damages.

Continue on next page.

Limitation of Liability (Cont.)

In no event shall liability attached to TC Communications, Inc. unless notice in writing is given to TC Communications, Inc. within ten days of the occurrence of the event giving rise to such claim.

TC Communications, Inc. shall not be responsible for delays or non-deliveries directly or indirectly resulting from or contributed to by foreign or domestic embargoes, seizure, fire, flood, explosion, strike, act of God, vandalism, insurrection, riot, war, or the adoption or enactment of any law, ordinances, regulation, or ruling or order or any other cause beyond the control of TC Communications, Inc.

TC Communications, Inc. shall not be responsible for loss or damage in transit and any claims for such loss or damage shall be filed by the purchaser with the carrier.