

TC3240 4-Port Switching/Bridging Ethernet Fiber Optic Media Converter with Rate Control

User's Manual Rev 1.5

Rev 1.5
TC3240 4-Port Switching/Bridging Ethernet Fiber Optic Media Converter with Rate Control
MNL-32400-01-15



TC Communications, Inc. 17881 Cartwright Road - Irvine, CA 92614

Tel: (949) 852-1972 Fax: (949) 852-1948 Web Site: www.tccomm.com Email: sales@tccomm.com

Table of Contents

1	User's Manual	1-1
1.1	Scope	1-1
1.1.1	User's Manual Content	1-1
1.1.1.1	Content Description	1-2
2	Overview	2-4
2.1	Features	2-4
2.2	Description	2-4
2.3	Site Selection Criteria	2-5
2.4	Mechanical Installation	2-5
2.5	Front Panel Connectors and Indicators	2-7
2.6	Rear Panel Connectors	2-7
2.7	Pin Assignments, Configurations and Default Settings	2-11
2.8	Default Software Configuration	2-13
3	Installation and Quick Start Guide	3-14
3.1	Unpacking the Unit	3-14
3.2	Equipment Location	3-14
3.3	Dry Contact Alarm Relay	3-14
3.4	Quick-Start Guide	3-15
3.4.1	Installation Procedure Summary	3-15
4	Management through Web	4-17
4.1	Login	4-17
4.2	Home Page	4-18
4.3	Unit Alarm	4-19
4.3.1	Unit Alarm Criteria	4-20
4.4	Port Statistics	4-20
4.4.1	Port Statistics: View Event Statistic	4-21
4.4.2	Port Statistics: View Port History	4-23
4.5	Basic Settings	4-24
4.6	IP Settings	4-25
4.7	Advanced Settings	4-26

4.7.1	About TC3240	4-27
4.7.2	Configuration File	4-28
4.7.2.1	Load Configuration File	4-28
4.7.2.2	Save Configuration File	4-29
4.7.3	Restart	4-29
4.7.4	Restore Defaults	4-30
4.7.5	TC3240 Firmware Upgrade.....	4-31
4.7.6	TC3240 Firmware Upgrade: Upgrade Now.....	4-32
4.7.7	Date and Time Settings	4-32
4.7.7.1	Clock Set.....	4-33
4.8	Port Settings.....	4-34
4.8.1	Local Loopback.....	4-35
4.9	Rate Limit	4-36
4.10	Virtual LAN	4-37
4.10.1	VLAN Static Settings.....	4-39
4.10.2	VLAN Port Settings	4-40
	SNMP Settings.....	4-43
4.11	Login Settings	4-44
4.11.1	Login User Setting	4-45
4.11.2	Login Group Setting	4-46
4.12	Logout	4-47
5	Management via Console/Telnet.....	5-48
5.1	Console/Telnet Management	5-48
5.1.1	Initial IP setting using the Console	5-49
5.1.2	Console Help	5-50
5.1.3	Telnet Settings	5-50
5.1.3.1	Unit Alarms.....	5-51
5.1.3.2	Port Statistics	5-51
5.1.3.3	Basic Settings.....	5-52
5.1.3.4	IP Settings	5-52
5.1.3.5	Advanced Settings	5-53
5.1.3.6	Port Settings.....	5-54
5.1.3.7	Rate Limit	5-54
5.1.3.8	VLAN.....	5-54

5.1.3.9 Login Settings.....	5-55
5.1.3.10 Update Settings.....	5-55
6 SNMP Management.....	6-57
6.1 SNMP Management.....	6-57
6.1.1 SNMP Third Party Management Software	6-57
6.1.2 SNMP Trap Management	6-58
7 Troubleshooting/Maintenance and Testing	7-59
7.1 General	7-59
7.1.1 All LEDs are "OFF"	7-59
7.1.2 "Alarm Condition" - ALM LED on the front panel.....	7-60
7.1.3 Optic Cable Types	7-60
7.1.4 Calculating the loss on the Fiber	7-60
8 Return Policy and Warranty	8-61
8.1 Return Policy.....	8-61
8.2 Warranty.....	8-61
Appendix A - Command Line Interface.....	8-62
Appendix B - Important Notice	8-63

List of Figures

Figure 1 TC3240 Standalone Unit Configuration	2-6
Figure 2 TC3240 Product Diagram - Dimensions	2-6
Figure 3 TC3240 Front Panel Connectors and Indicators.....	2-7
Figure 4 TC3240 Front Panel Connectors and Indicators.....	2-8
Figure 5 TC3240 Testing one TC3240	3-15
Figure 6 Web Application - Login Screen	4-17
Figure 7 Web Application – Home Page Screen.....	4-18
Figure 8 Web Application - Home: Physical Status.....	4-19
Figure 9 Web Application - Home: Physical Status.....	4-20
Figure 10 Web Application – Port Statistics	4-21
Figure 11 Web Application – Port Statistics: View Event Statistics.....	4-22
Figure 12 Web Application – Port Statistics: View History	4-23
Figure 13 Web Application – Basic Settings	4-24
Figure 14 Web Application – IP Settings	4-25
Figure 15 Web Application – Advanced Settings	4-26
Figure 16 Web Application – Advanced Settings: About TC3240.....	4-27
Figure 17 Web Application – Advanced Settings: Configuration File	4-28
Figure 18 Web Application – Advanced Settings: Load Configuration File	4-28
Figure 19 Web Application – Advanced Settings: Save Configuration File	4-29
Figure 20 Web Application – Advanced Settings: Restart TC3240.....	4-29
Figure 21 Web Application – Advanced Settings: Restore Default	4-30
Figure 22 Web Application – Advanced Settings: TC3240 Firmware Upgrade.....	4-31
Figure 23 Web Application – Advanced Settings: Upgrade From a Computer in the Network.....	4-32
Figure 24 Web Application – Advanced Settings: Date and Time Settings.....	4-33
Figure 25 Web Application – Advanced Settings: Clock Set.....	4-33
Figure 26 Web Application – Port Settings	4-34
Figure 27 Web Application – Port Settings: Local Loopback	4-35
Figure 28 Web Application – Rate Limit Settings.....	4-36
Figure 29 Web Application – Virtual LAN.....	4-37
Figure 30 Web Application – VLAN: Edit VLAN	4-38

Figure 31 Web Application – VLAN: Static Settings.....	4-39
Figure 32 Web Application – VLAN: Port Settings: Port Type.....	4-40
Figure 33 Web Application – SNMP Settings.....	4-43
Figure 34 Web Application – SNMP: Traps	4-44
Figure 35 Web Application – Login Settings	4-44
Figure 36 Web Application – Login Settings: Add New User	4-45
Figure 37 Web Application – Login Settings: Edit User	4-45
Figure 38 Web Application – Login Settings: Add New Group.....	4-46
Figure 39 Web Application – Login Settings: Edit Group	4-47
Figure 40 Web Application – Log Out	4-47
Figure 41 Terminal Settings - Console Port Configuration.....	5-49
Figure 42 Telnet Help Menu	5-51
Figure 43 Telnet Unit Alarm Menu	5-51
Figure 44 Telnet Port Statistics Menu	5-52
Figure 45 Telnet Basic Settings Menu	5-52
Figure 46 Telnet IP Settings Menu	5-53
Figure 47 Telnet Advanced Settings Menu	5-53
Figure 48 Telnet Port Settings Menu	5-54
Figure 49 Telnet Rate Limit Menu.....	5-54
Figure 50 Telnet VLAN Menu	5-55
Figure 51 Telnet Login Settings Menu	5-55
Figure 52 Telnet Remote Update Menu.....	5-56
Figure 53 Third Party SNMP Manager.....	6-57
Figure 54 SNMP Trap Display	6-58
Figure 55 Reference for Calculating Fiber Loss.....	7-60

List of Tables

Table 1	TC3240 Power and Indicators	2-9
Table 2	TC3240 Ethernet Switch	2-9
Table 3	TC3240 Console	2-10
Table 4	Physical/Electrical	2-10
Table 5	Compliance Items	2-11
Table 6	Pin Assignments	2-11
Table 7	DC Power Connector Contacts	2-12
Table 8	Console Port	2-12
Table 9	Dry Contact Relay Switch Specifications	2-12
Table 10	Network Management (WEB/SNMP/CLI/TELNET).....	2-13
Table 11	SNMP	2-13
Table 12	Ethernet Port Settings.....	2-14
Table 13	TC3240 Filter Actions	4-41

1 User's Manual

TC3240 Switching/Bridging Ethernet Fiber Media Converter with Rate Control

1.1 Scope

This User Manual contains a description of TC Communications Ethernet, Fiber Optic, Media Converter. The TC3240 is frequently used by Data Service Providers to control the bandwidth they offer to customers. It is also used for its ability to transmit over long distances (100km or farther) without connecting to additional hardware, e.g. a Switch or a Router. The Hardened Temperature option enables it to be used in extreme environments (-20C to +70C) and Extreme Temp (-40C to +80C).

Content and Format

The content of the User's Manual is intended to provide clear, complete descriptions of the following information about the system:

- ◆ Overview: Features, Description, Site Selection and Mechanical Installation.
- ◆ Product Diagram, Pin Assignments and Configuration
- ◆ Installation and Quick-Start Guide.
- ◆ Web Management: Status, Alarms, IP Settings and Advanced Configuration.
- ◆ Console Management: Settings, Telnet and Firmware.
- ◆ SNMP Management. Query, 3rd Party Software and Trap Management.
- ◆ Troubleshooting, Maintenance and Loopback Testing.
- ◆ Return Policy and Warranty Information.

1.1.1 User's Manual Content

The User's Manual contains the following:

- a. Overview;
- b. Installation and Quick-Start Guide;
- c. Management through Web;

- d. Management through Console/Telnet;
- e. SNMP Management;
- f. Troubleshooting/Maintenance & Testing;
- g. Return Policy and Warranty;
- h. Command Line Interface;
- i. Important Notice

1.1.1.1 Content Description

The User's Manual is a comprehensive document that describes the realized benefits from deployment of the TC Communications TC3240 Switching/Bridging Fiber Media Converter in a network design.

1.1.1.1.1 Overview

- a. The Overview describes the TC3240 as a Switching/Bridging Ethernet Fiber Media Converter with Rate Control. It consists of 3 ports of 10/100 Base-T copper and 1 port of 100FX fiber. The copper ports support Auto-Negotiation and Auto-Sensing features, and the optic port supports multimode or single mode optics.

1.1.1.1.2 Installation and Quick-Start Guide

- a. The Installation and Quick-Start Guide describe how to unpack, inspect and perform initial setup of the TC3240 unit in a typical network application.

1.1.1.1.3 Management through Web Application

- a. The Web Management application is an integral interface designed into your TC3240. This simple interface may be accessed through any of the 3 Ethernet ports on the front of the unit. In this section we step you through the setup and initialization of the unit.

1.1.1.1.4 Management through Console Telnet Session

- a. The TC3240 may also be accessed over your LAN using a hyper-terminal or Telnet session to configure the unit. In this section we will describe how to interface with the unit in a Telnet session to set the system configuration.

1.1.1.1.5 SNMP Management

- a. The TC3240 comes standard with a built in SNMP Agent. The MIB file that TC provides is compatible and a may be run on any 3rd party SNMP Management software.

1.1.1.1.6 Troubleshooting/Maintenance and Testing

- a. In the Troubleshooting and Maintenance section we will provide you with the tools to manage your TC3240 for the lifecycle of the product. This section contains detailed troubleshooting aids and test criteria.

1.1.1.1.7 Return Policy and Warranty

- a. In the event you need servicing of your TC3240, this section of the manual provides detailed instructions for our Return Policy and Warranty Conditions.

2 Overview

The TC3240 10/100M 4-port Switching Fiber Optic Ethernet Media Converter converts or connects 10/100Base-TX (UTP) networks to 100Base-FX (fiber optic) networks.

2.1 Features

- 3 Ports 10/100 Base-T with Auto-Negotiation and Auto-Sensing
- 1 Port 100FX: Multimode or Single mode
- Rate Control (32Kbps to 100Mbps, in 32Kbps increments)
- Ethernet VLAN (IEEE 802.1Q)
- Hi-Temp (-20°C to +70°C) and Extreme Temp (-40°C to +80°C) Versions (optional)
- One Fiber Bi-Directional Optic (optional)
- Huge Frame Support (1916 bytes)
- Management Using Web, SNMP, Console, and Telnet
- Distances up to 2km on Multimode (1310nm) and 100km on Single Mode (1310nm/1550nm)
- Power Redundancy
- Power Supplies Available: 115/230VAC, 12 VDC, 24VDC, or -48VDC
- Local Dry Contact Alarm Relay
- Network Time Protocol (NTP)
- Rackmount or Standalone

2.2 Description

The TC3240 10/100M 4-port Switching Fiber Optic Ethernet Media Converter converts or connects 10/100Base-TX (UTP) networks to 100Base-FX (fiber optic) networks. It includes 3 Ports 10/100 Base-T and 1 Port 100FX: Multimode or Single mode over single mode (1300/1550nm) or multimode fiber (1300nm).

Rate Control gives users, especially data service providers, the ability to control or limit bandwidth. Data rates for Rate Control can be set at 32K, 64K, 96K...99.9M, 100M, at 32K increments. The TC3240 can be managed through Web, SNMP, Telnet, or Serial Console. Password protection is provided. The Huge Frame feature enables the TC3240 to handle packets up to 1916 bytes.

The TC3240 includes a built-in switch that enables distances up to 100km without additional hardware (e.g. Switch or Router). Transparent to the network, it operates effectively even during high demand traffic loads.

Configuration settings can be stored and recovered to simplify network administration, and firmware can be remotely upgraded. Virtual LAN (VLAN) and Network Time Protocol (NTP) are supported. The TC3240 supports single mode distances up to 100 km (1550nm laser) and works with all standard fiber optic cable (depending on the type of optics ordered). A One Fiber Bi-Directional single mode version is available. Fiber optic connectors are ST, FC or SC. The UTP connector is RJ-45 Female.

Standard temperature range is -10°C to 50°C. Optionally, the high-temp version ranges -20°C to 70°C. The optional extreme-temp version ranges from -40°C to 80°C, exceeding NEMA and CalTrans specifications.

Power source options include 12 VDC, 24VDC, -48VDC or 115/230VAC with an with an external power cube, and power redundancy is standard. TC3240 is available standalone or rack mount (up to 10 cards per Rack Assembly).

2.3 Site Selection Criteria

The following is a site selection guideline to select a proper installation site for the TC3240.

- Location of the TC3240 unit should be part of the central office equipment layout design. Considerations should be given to entrance cable routing.
- The installation site should provide proper room for adequate ventilation and cable routing. Reserve at least 0.5 m at the front and rear of the unit for human access, cables, and air flow.
- The site should provide a stable environment. The operating area should be clean and free from extremes of temperature, humidity, shock, and vibration.

2.4 Mechanical Installation

The TC3240 is a Standalone or Rack-mount unit, which offers redundant power supplies as a standard. The power supplies are 2 Plug-in boards located on the rear panel.

The TC3240 offers 5 different power supply options:

- 115/230VAC
- 12VDC
- 24VDC
- 48VDC



Figure 1 TC3240 Standalone Unit Configuration

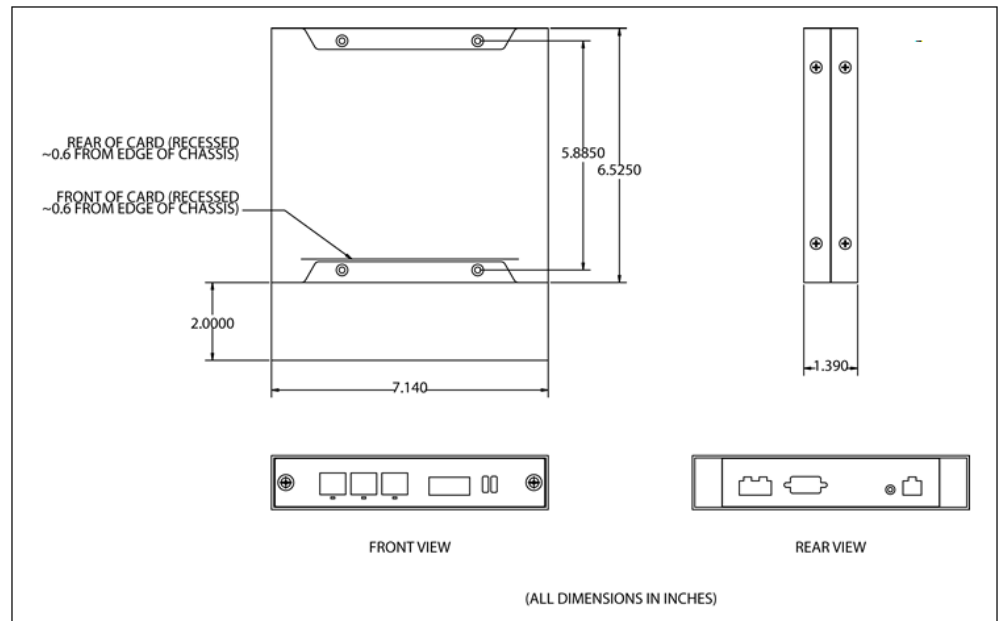

Figure 2 TC3240 Product Diagram - Dimensions

2.5 Front Panel Connectors and Indicators

The TC3240 front panel consists of 3 RJ-45 ports for Ethernet connectivity and one SC fiber port connector as shown in Figure 3 below. The RJ-45 connectors furnish LED indications for Link Established/Activity, Full Duplex Operation/Collision Detection and 100Mbps Operation. The Fiber Optic Connector also furnishes LED indication for Link Activity, Full Duplex Operation and 100Mbps Operation. Unit LEDs include: Alarm Indication, Power Source A and Power Source B available, Power On (VCC) Indication and Watchdog Timer Indication.

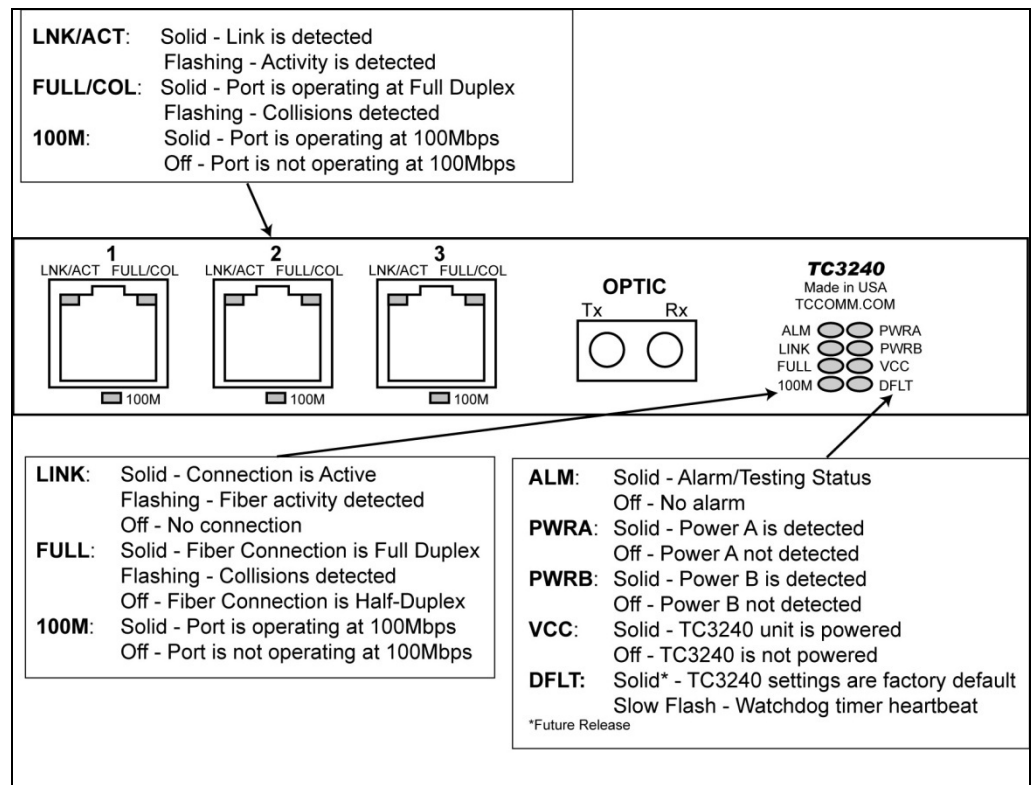

Figure 3 TC3240 Front Panel Connectors and Indicators

2.6 Rear Panel Connectors

The TC3240 rear panel consists of two power connectors for power A and power B, a serial console RS-232 DB9 connector for management/telnet, a reset button, and a dry contact alarm relay. To reset the unit back to factory default settings, hold the “reset” button for five seconds while the unit is powered on.

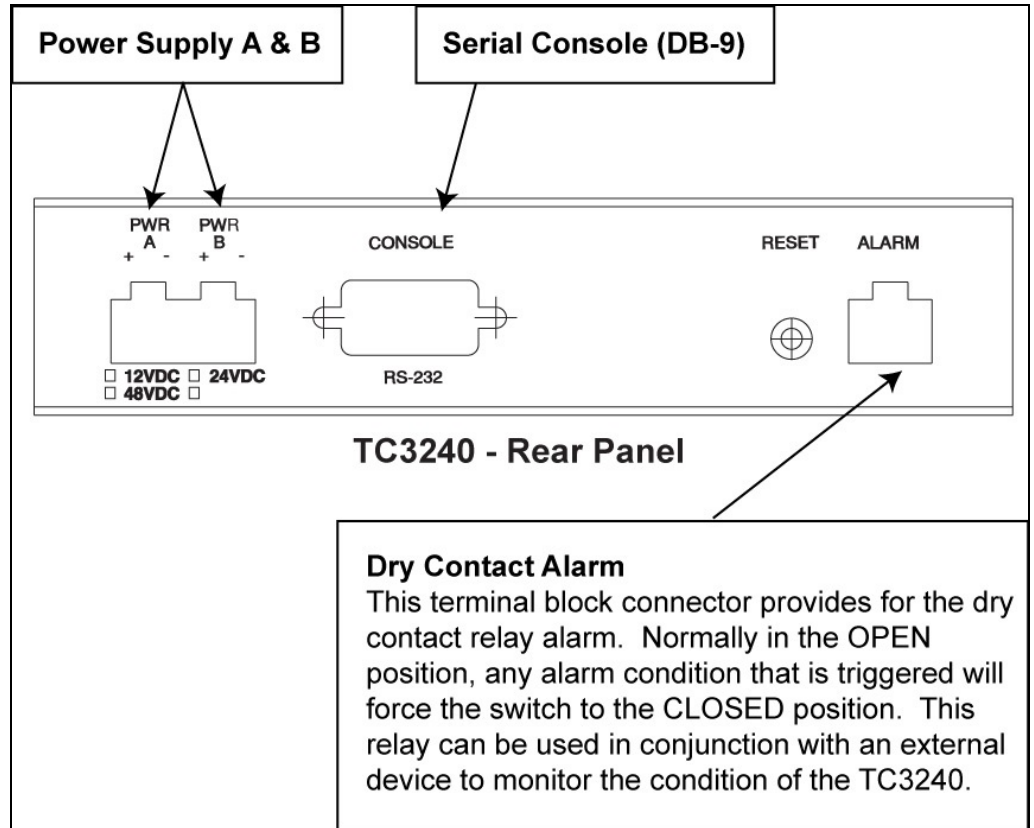

Figure 4 TC3240 Front Panel Connectors and Indicators

2.6.1.1.1 Optical, Line and Port Specifications

Optical Fiber Interface	
Wavelength	1310 nm Multi-mode
	1310/1550 nm Single Mode
Connector	SC, ST, FC
Loss Budget	15dB Multimode 1310nm @62.5/125µm
	Up to 25 dB Single Mode 1310nm @9/125µm * Up to 30 dB Single Mode 1550nm @9/125µm * * (Dependent on what is ordered) (Contact factory for higher loss budgets)

Table 1 TC3240 Power and Indicators

Ethernet Switch
<ul style="list-style-type: none"> • 3 port 10/100 Mbps half/ full duplex Ethernet Switch • Support VLAN and Ethernet Huge Frame support

Table 2 TC3240 Ethernet Switch

Console	
Connector	Serial DB-9 on rear panel
Electrical	RS232 Interface
Baud Rate	9600 8-N-1

Table 3 TC3240 Console

Physical/Electrical	
Dimensions	7.14 x 1.39 x 6.53 in / 18.13 x 3.53 x 16.59 cm (W x H x D)
Mounting	Standalone or 19 inch rack mount
Power Source (AC)	115/230 VAC, 50/ 60 Hz
Power Source (DC)	12VDC 24VDC 48VDC
Power Protection	Standard Redundancy
Temperature Range	-10°C to 50°C (Standard); -20°C to 70°C (High Temp); -40°C to 80°C (Extreme Temp);

Table 4 Physical/Electrical

Compliance Items
EMI/EMC EN55022 ANSI.403-1999, ANSI T1.408, AT&T TR 62411 ITU G.703, G.704, G.706, G.736, G.775, G.823, I.431, O.151, O.161 ETSI ETS 300 166, JTG.703, JTI.431, TBR12, TBR13, CTR4 CSA 60950 FCC PART 15 CLASS A NEMA TS-2 CALTRANS TEES

Table 5 Compliance Items

2.7 Pin Assignments, Configurations and Default Settings

Pin definition and connections are listed below. Console port can be connected via RS232 interface to a PC using HyperTerminal configured for VT100 or any VT100 terminal emulator.

Pin Assignments			
Console DB-9 Port Pin Assignment		Ethernet RJ-45 Port Pin Assignment	
Pin Number	Signal	Pin Number	Signal
2	Transmit Data	1	TPTX+
3	Receive Data	2	TPTX+
5	Signal Ground	3	TPRX+
		6	TPRX+
		7	Chassis GND
		8	Chassis GND

Table 6 Pin Assignments

DC Power Connector		
Pin Number	Signal	Description
1 (Left)	+V	+DC Return
2 (Right)	-V	-DC 24/48 V

Table 7 DC Power Connector Contacts

Console Port		
Configuration	Option	Default
Baud Rate	9600	9600
Data Length	8-bits	8-bits
Stop Bits	1-bit	1-bit
Parity	None	None

Table 8 Console Port

Dry Contact	
Max Switch Voltage	100 VDC
Switch Current	0.5 Amp
Max Carry Current	1.2 Amp
Contact Resistance	0.2 Ohm

Table 9 Dry Contact Relay Switch Specifications

2.8 Default Software Configuration

Network Management (WEB/SNMP/CLI/TELNET)		
Configuration	Option	Default
IP Address		192.168.1.1
Subnet Mask		255.255.255.0
Gateway IP		0.0.0.0
Username		admin
Password		admin
User		Administrator

Table 10 Network Management (WEB/SNMP/CLI/TELNET)

SNMP		
Configuration	Option	Default
Read-Only Community Name		public
Read-Write Community Name		private
Trusted Peer	IP, Subnet, All	All
SNMP Traps	Enable, Disable	Disable

Table 11 SNMP

Ethernet		
Configuration	Option	Default
Ports	Enable, Disable	Enable
Speed/Duplex	10/100Mbps, Full/Half/Auto	Auto-negotiation
Flow Control	Enable, Disable	Disable

Table 12 Ethernet Port Settings

3 Installation and Quick Start Guide

3.1 Unpacking the Unit

Before unpacking any equipment, inspect all shipping containers for evidence of external damage caused during transportation. The equipment should also be inspected for damage after it is removed from the container(s). Claims concerning shipping damage should be made directly to the pertinent shipping agencies. Any discrepancies should be reported immediately to the Customer Service Department at TC Communications, Inc at (949) 852-1973.

3.2 Equipment Location

The TC3240 should be located in an area that provides adequate light, work space, and ventilation. Location of the TC3240 unit should be part of the central office equipment layout design. Considerations should be given to entrance cable routing. The installation site should provide proper room for adequate ventilation and cable routing. Reserve at least 0.5 m at the rear of the unit for human access, cables, and air flow. Avoid locating it next to any equipment that may produce electrical interference or strong magnetic fields, such as elevator shafts or heavy duty power supplies. As with any electronic equipment, keep the unit from excessive moisture, heat, vibration, and freezing temperatures.

3.3 Dry Contact Alarm Relay

The terminal block connector on the rear panel (labeled "ALARM" provides for the dry contact relay alarm (see Figure 2). Normally in the OPEN position, any loss of optical signal will trigger an alarm condition and force the switch to the CLOSED position (the "ALM" LED

will light solidly). This relay can be used in conjunction with an external device to monitor the condition of the TC3240. The alarm switch will only be activated when any alarm condition is triggered

Note: The Console port connector (RJ-45 connector) is not used for data, it is strictly used to configure and manage the TC3240. Please refer to Section 5: Management via Console/Telnet.

3.4 Quick-Start Guide

This section describes the basic TC3240 configuration and setup.

3.4.1 Installation Procedure Summary

Quick Start Guide for your TC3240

The TC3240 is designed for quick and easy installation.

1. Prepare 2 PCs to have the following settings:

PC#1

IP address: 192.168.1.101
Subnet mask: 255.255.255.0

PC#2

IP address: 192.168.1.102
Subnet mask: 255.255.255.0

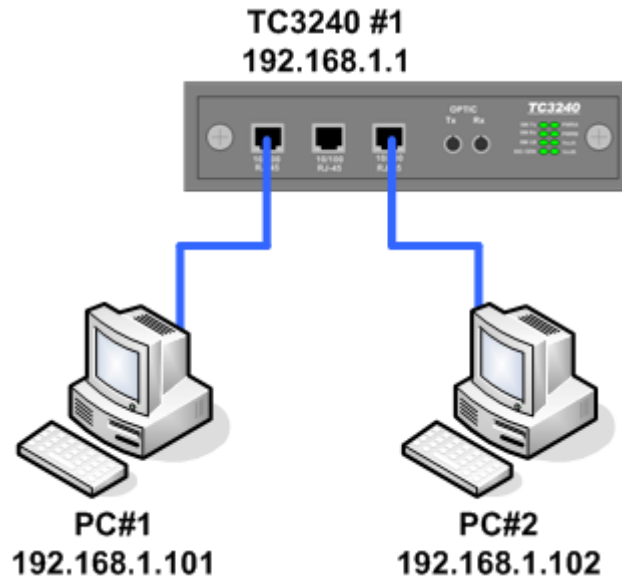
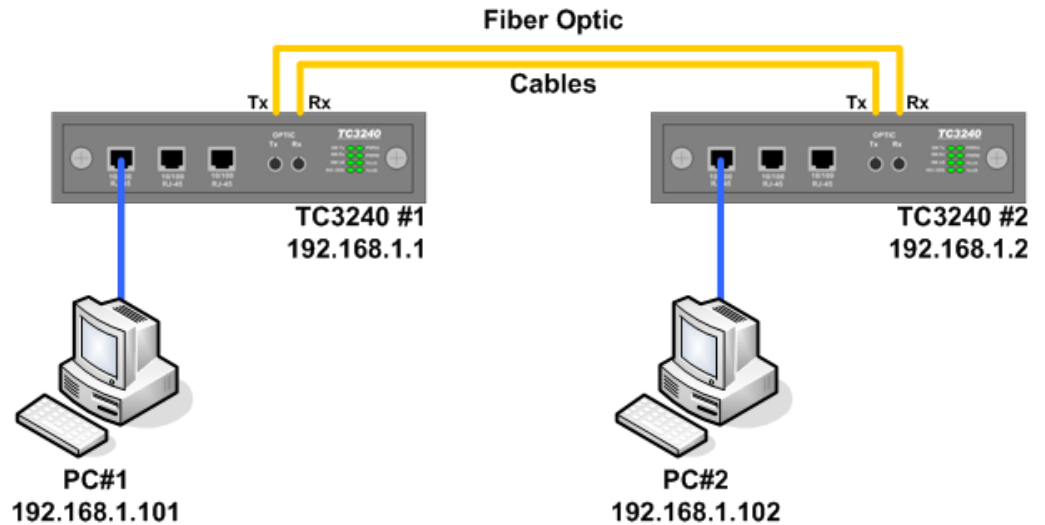

Figure 5 TC3240 Testing one TC3240

2. Connect the power to the TC3240.

3. Using a CAT-5 cable, connect both PCs to a TC3240 Ethernet port.

4. On PC#1, open Command Prompt and type *ping 192.168.1.102*. The ping should be successful. On PC#2, open Command Prompt and type *ping 192.168.1.101*. The ping should be successful as well.



5. Because the TC3240 default IP address is 192.168.1.1, the IP of one of the TC3240 units must be changed. We will define TC3240#1 as having an IP address of 192.168.1.1, and TC3240#2 as having an IP address of 192.168.1.2. Using PC#1, log into one of the TC3240 by opening a web browser and typing *192.168.1.1* into the address bar.

6. Click on “IP Settings” to set up the new IP address for the TC3240. (192.168.1.2). Make sure that the subnet mask is 255.255.255.0.

Note 1: after the IP has been applied, you will need to enter this new IP address in your web browser.

Note 2: On both PCs, please go into command prompt and type *arp -d 192.168.1.1*. This will clear the cache of your computer and will prevent any IP conflicts on your PCs.

7. Connect the optic ports using the correct type of fiber cables for the media converter. Connect TC3240#1’s TX to TC3240#2’s RX, and connect TC3240#1’s RX to TC3240#2’

8. Connect PC#1 to TC3240#1, and connect PC#2 to TC3240#2.

9. Using PC#1, first ping *192.168.1.2* and then ping *192.168.1.102*.

10. Using PC#2, first ping *192.168.1.1* and then ping *192.168.1.101*.

Category 5 Cable Notes:

The TC3240 Ethernet ports are auto-sensing and auto-negotiating. This allows the use of either a straight through CAT5 cable or a cross-over CAT5 cable. This also means the TC3240 can detect the speed of the Ethernet connection without having to configure it.

4 Management through Web

4.1 Login

The management web page can be accessed through any of the 3 Ethernet ports on the front panel (RJ-45 connectors) using a PC and a web browser. The TC3240's default IP address is 192.168.1.1. Thus, the PC's IP address must be set within the range of 192.168.1.2 to 192.168.1.254 (make sure no other network device is sharing this IP address), and with subnet mask of 255.255.255.0.

Attention: If you are unsure about the settings, contact your network administrator. Improper settings may result in disruption of the existing network.

Once you enter the IP address into your web browser and press Enter, you will see the login window where you will be prompted to enter a username and password. **Both the user name and password are "admin"**.



The screenshot shows the login interface for the TC3240 web application. At the top, there is a header with the TC Communications logo on the left, which includes the text 'TC COMMUNICATIONS' and 'THE LEADER IN FIBER OPTIC CONNECTIVITY'. To the right of the logo, the product name 'TC3240 10/100 Base-T to Fiber Optic Bridged Media Converter' is displayed. Below the header, the main content area is titled 'Login'. A message 'User has logged out, please login again:' is centered above two input fields: 'User Name:' and 'Password:'. An 'OK' button is positioned at the bottom right of the form area.

Figure 6 Web Application - Login Screen

4.2 Home Page

The Home Page displays an overall view of the TC3240.

Unit Status: Displays the time duration the TC3240 has been powered on. It separates the time into days, hours, minutes, and seconds. It also displays the voltage and current usage as well as the detection for power A and B.

Port Status: Displays the status of all three Ethernet RJ-45 ports and the Fiber port.

The Ethernet ports & Fiber port show the current status for: Port In Use, Speed/Duplex, Flow Control and Link status.

Rate Limit Status: Displays the current Ethernet ports & Fiber port status for the Transmit Limit and Receive Limit.

Port	Port In Use	Speed / Duplex	Flow Control	Link Status
RJ45 #1	Enabled	Auto-Negotiate	Disabled	Not Connected
RJ45 #2	Enabled	Auto-Negotiate	Disabled	Not Connected
RJ45 #3	Enabled	Auto-Negotiate	Disabled	100Mbps/Full
Fiber #1	Enabled	100Mbps/Full	Disabled	Not Connected

Port	Transmit Limit	Receive Limit
RJ45 #1	Disabled	Disabled
RJ45 #2	Disabled	Disabled
RJ45 #3	Disabled	Disabled
Fiber #1	Disabled	Disabled

Figure 7 Web Application – Home Page Screen

4.3 Unit Alarm

The Unit Alarm page displays the alarm status of the entire TC3240 unit. Alarm trigger criteria can be set on this page. User must click on "Apply" for changes to take effect.

Unit Alarm Status: Displays the TC3240 alarm condition.

Unit Alarm Settings:

Dry Contact Enabled: Allow an external device to signal alarm condition.

Alarm Trigger Criteria: Click the 'Modify' button to configure the alarm triggers. Please refer to Section 4.3.1.

Clear Alarm: Clears all alarm signals on the TC3240. If an existing alarm is still present and the page is refreshed, the alarm condition will reappear.

Alarm Cut-Off (ACO): Clears all alarm signals on the TC3240. If an existing alarm is still present and the page is refreshed, the alarm condition will still be off. Only a new alarm that is triggered will change the Unit Alarm Status to on.

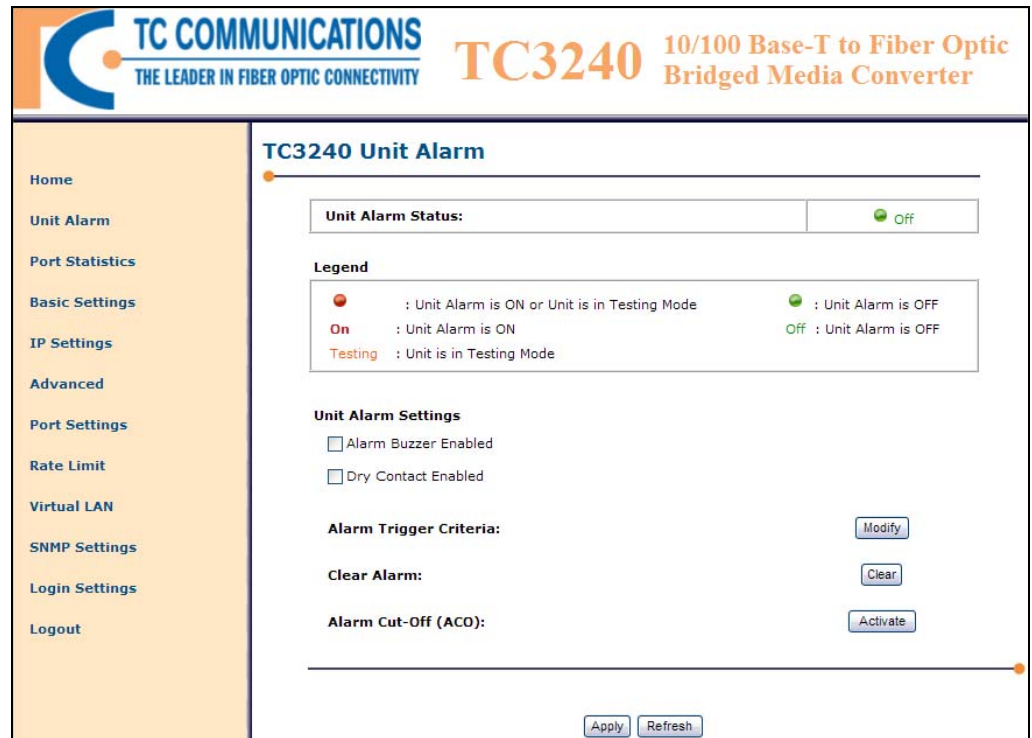

Figure 8 Web Application - Home: Physical Status

4.3.1 Unit Alarm Criteria

The Unit Alarm Criteria page categorizes all possible alarm triggers for RJ-45 ports, Fiber port. The desired alarm triggers can be configured on this page. This page is accessible from the Unit Alarm page. At the Alarm Trigger Criteria section, click on "Modify" to reach this page.

The following are the options for the RJ-45 port alarms: **RJ-45 Link Triggers, Fiber Link Triggers.**

The screenshot displays the web application interface for the TC3240. At the top, the logo for TC COMMUNICATIONS is on the left, with the text 'THE LEADER IN FIBER OPTIC CONNECTIVITY'. To the right, the model number 'TC3240' and the device name '10/100 Base-T Fiber Optic Bridged Media Converter' are shown. A navigation menu on the left lists various settings: Home, Unit Alarm, Port Statistics, Basic Settings, IP Settings, Advanced, Port Settings, Rate Limit, Virtual LAN, SNMP Settings, and Login Settings. The main content area is titled 'Unit Alarm Criteria' and contains the instruction: 'Select from the following to indicate what options will trigger the unit alarm...'. Under 'RJ45 Link Triggers', there are three checkboxes for 'RJ45 #1', 'RJ45 #2', and 'RJ45 #3', all of which are currently unchecked. Under 'Fiber Link Triggers', there is one checkbox for 'Fiber #1', which is checked. At the bottom right of the form, there are three buttons: 'OK', 'Apply', and 'Close'.

Figure 9 Web Application - Home: Physical Status

4.4 Port Statistics

The Ethernet Port Statistics offers a comprehensive overview of the Ethernet traffic passing through the TC3240. It allows for a history of statistics that can be saved in regular intervals. The Network Administrator can define the save rate in increments of minutes. The network administrator can also define the refresh rate of this page.

Note: Setting the Save Rate to less than 5 minutes will damage the flash memory.

The Statistics Summary also separates the traffic into transmit (Tx) and receive (Rx) for each of the 3 Ethernet ports. The key Ethernet statistics that are monitored are Frames per Second (FPS), Bytes per Second (BPS), and Bandwidth Usage Percentage (BU%).

Statistics of Ethernet ports #1, #2, and #3 are independently monitored and recorded, and a Port History and Event Statistic can be accessed by the respective icons at the right of the Statistics Summary under the View column.

For example:

Click the Port Statistics link on the left side of the page. You will see the page as in the figure below. It will show the bandwidth status and history and/or event of the RJ-45 port.

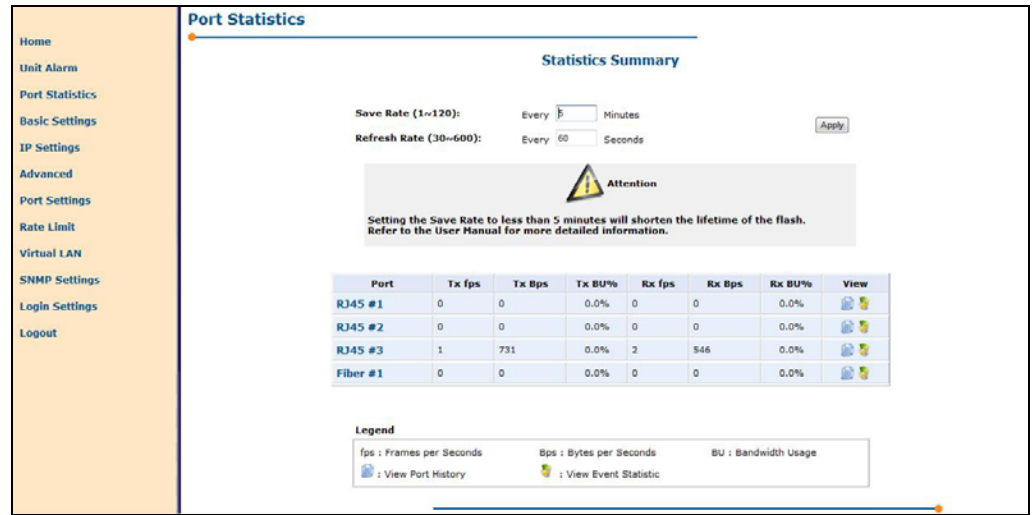

Figure 10 Web Application – Port Statistics

4.4.1 Port Statistics: View Event Statistic

When you are at the Port Statistics page, click on the “View Event Statistic” icon under the View column to display the Event Statistics of the RJ45 #.

- Home
- Unit Alarm
- Port Statistics**
- Basic Settings
- IP Settings
- Advanced
- Port Settings
- Rate Limit
- Virtual LAN
- SNMP Settings
- Login Settings
- Logout

Port Statistics

RJ45 # 3 Event Statistics

Statistics Summary

Tx fps	Tx Bps	Tx BU%	Rx fps	Rx Bps	Rx BU%	History
1	1264	0.0%	3	407	0.0%	

Total Tx (KBytes)	Total Rx (KBytes)
0	0

Event Statistics

Event	Count
Tx Broadcast:	0 Packets
Tx Multicast:	0 Packets
Tx Unicast:	0 Packets
Tx Pause:	0 Packets
Tx Total Collision:	0 Packets
Tx Excess Collision:	0 Packets
Tx Single Collision:	0 Packets
Tx Multi Collision:	0 Packets
Rx Broadcast:	0 Packets
Rx Multicast:	0 Packets
Rx Unicast:	0 Packets
Rx Pause:	0 Packets
CRC Error:	0 Packets
Oversize Error:	0 Packets
Undersize Error:	0 Packets

Figure 11 Web Application – Port Statistics: View Event Statistics

4.4.2 Port Statistics: View Port History

When you are at the Port Statistics page, click on the “Port History” icon under the View column to display the Port # History.

TC COMMUNICATIONS
THE LEADER IN FIBER OPTIC CONNECTIVITY

TC3240 10/100 Base-T to Fiber Optic Bridged Media Converter

Port Statistics

RJ45 #1 Port History - Page 1

Statistics Summary

Tx fps	Tx Bps	Tx BU%	Rx fps	Rx Bps	Rx BU%	History	Event
0	0	0.0%	0	0	0.0%	Page 1	

Port History

Row	Date	Time	Rx fps	Rx Bps	Rx BU%	Tx fps	Tx Bps	Tx BU%
1	01.01.2003	00:05	0	0	0.0%	0	0	0.0%
2	01.01.2003	00:00	0	0	0.0%	0	0	0.0%
3	0	0	0	0	0.0%	0	0	0.0%
4	0	0	0	0	0.0%	0	0	0.0%
5	0	0	0	0	0.0%	0	0	0.0%
6	0	0	0	0	0.0%	0	0	0.0%
7	0	0	0	0	0.0%	0	0	0.0%
8	0	0	0	0	0.0%	0	0	0.0%
9	0	0	0	0	0.0%	0	0	0.0%
10	0	0	0	0	0.0%	0	0	0.0%
11	0	0	0	0	0.0%	0	0	0.0%
12	0	0	0	0	0.0%	0	0	0.0%
13	0	0	0	0	0.0%	0	0	0.0%
14	0	0	0	0	0.0%	0	0	0.0%
15	0	0	0	0	0.0%	0	0	0.0%
16	0	0	0	0	0.0%	0	0	0.0%
17	0	0	0	0	0.0%	0	0	0.0%
18	0	0	0	0	0.0%	0	0	0.0%
19	0	0	0	0	0.0%	0	0	0.0%
20	0	0	0	0	0.0%	0	0	0.0%
21	0	0	0	0	0.0%	0	0	0.0%
22	0	0	0	0	0.0%	0	0	0.0%
23	0	0	0	0	0.0%	0	0	0.0%
24	0	0	0	0	0.0%	0	0	0.0%

Close Clear History Refresh

Figure 12 Web Application – Port Statistics: View History

4.5 Basic Settings

Click the "Basic Setting" link on the left side of the page and you will see the window below, and you can begin the configurations. You may change the values of the fields as you like.

The screenshot shows a web application interface for configuring a switch. On the left is a vertical navigation menu with the following items: Home, Unit Alarm, Port Statistics, Basic Settings (highlighted), IP Settings, Advanced, Port Settings, Rate Limit, Virtual LAN, SNMP Settings, Login Settings, and Logout. The main content area is titled "Basic Switch Settings" and contains a table of configuration fields:

Name	<input type="text"/>
Location	<input type="text"/>
Contact	<input type="text" value="network@admin.com"/>
Description #1	<input type="text"/>
Description #2	<input type="text"/>
Description #3	<input type="text"/>

Below the table is an "Apply" button.

Figure 13 Web Application – Basic Settings

4.6 IP Settings

To configure the IP settings for Management and User, click the "IP Settings" link on the left side of the page. On the IP settings window, enter the IP addresses, Subnet Masks and Default Gateways as shown on the figure below. Domain Name Systems (DNS) can also be entered here. Only the Login Level Admin has access to both the Management and User IP settings. This gives the Administrator full control of both IP settings. The user has access to only the User IP settings.

IP Address Aliases allows for the unit to be access from different IPs. For example, a service provider may want the TC3240 in the 192.168.1.x network. If a customer needs access to this unit but not access to the service provider's network, an additional IP for the TC3240 can be set up, such as 30.30.0.100.

The screenshot displays the 'IP Settings' configuration page. On the left is a sidebar with the following menu items: Home, Unit Alarm, Port Statistics, Basic Settings, IP Settings (highlighted), Advanced, Port Settings, Rate Limit, Virtual LAN, SNMP Settings, Login Settings, and Logout. The main content area is titled 'IP Settings' and contains the following sections:

- Current Settings**
 - Current IP Address: 192.168.254.187
 - Current Subnet Mask: 255.255.255.0
 - Current Default Gateway: 0.0.0.0
 - Physical Address: 04:18:b4:90:b9:0b
- IP Settings**
 - IP Address:
 - Subnet Mask:
 - Default Gateway:
- DNS Server**
 - Primary DNS Server:
 - Secondary DNS Server:
- IP Address Aliases** (with a 'New IP Address' button)

At the bottom of the page are three buttons: OK, Apply, and Cancel.

Figure 14 Web Application – IP Settings

4.7 Advanced Settings

This page gives you access to the advanced settings for the TC3240. Click on the corresponding icon to access the advanced setting.



Figure 15 Web Application – Advanced Settings

4.7.1 About TC3240

The About TC3240 page displays technical information regarding the TC3240 hardware and software. Contact information for TC Communications is also displayed.

The screenshot shows a web application interface. On the left is a vertical sidebar with a light orange background, containing a list of navigation links: Home, Unit Alarm, Port Statistics, Basic Settings, IP Settings, Advanced, Port Settings, Rate Limit, Virtual LAN, SNMP Settings, Login Settings, and Logout. The 'Advanced' link is highlighted. The main content area is titled 'About TC3240' and contains the following information:

Product Number: TC3240
Firmware Version: 1.0.0
Hardware Version: 1.1.0
Hardware Serial Number: 0000000

Contact TC Communications:

Sales
Email: sales@tccomm.com
Phone: (800) 569-4736 (Domestic Only)
Office Hours: 7:00 AM to 4:00 PM (Pacific Standard Time) Monday through Friday

Technical Support
Email: technicalsupport@tccomm.com
Phone: (949) 852-1973
Office Hours: 8:30 AM to 5:15 PM (Pacific Standard Time) Monday through Friday

Mailing and Shipping: TC Communications, Inc.
17881 Cartwright Road
Irvine, California, USA 92614

Web site: http://www.tccomm.com
Email: info@tccomm.com
Phone: (949) 852-1972
Fax: (949) 852-1948

At the bottom right of the main content area, there is a 'Close' button.

Figure 16 Web Application – Advanced Settings: About TC3240

4.7.2 Configuration File

The Configuration File page allows the Network Administrator to save current TC3240 settings or load previously saved TC3240 settings.

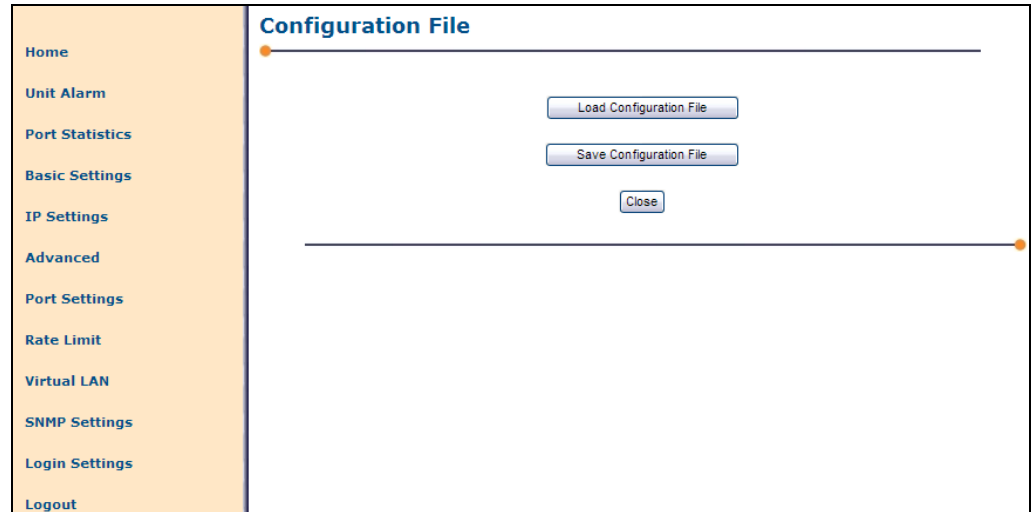

Figure 17 Web Application – Advanced Settings: Configuration File

4.7.2.1 Load Configuration File

Load Configuration File: This page allows the user to choose the configuration file that he/she wishes to load.

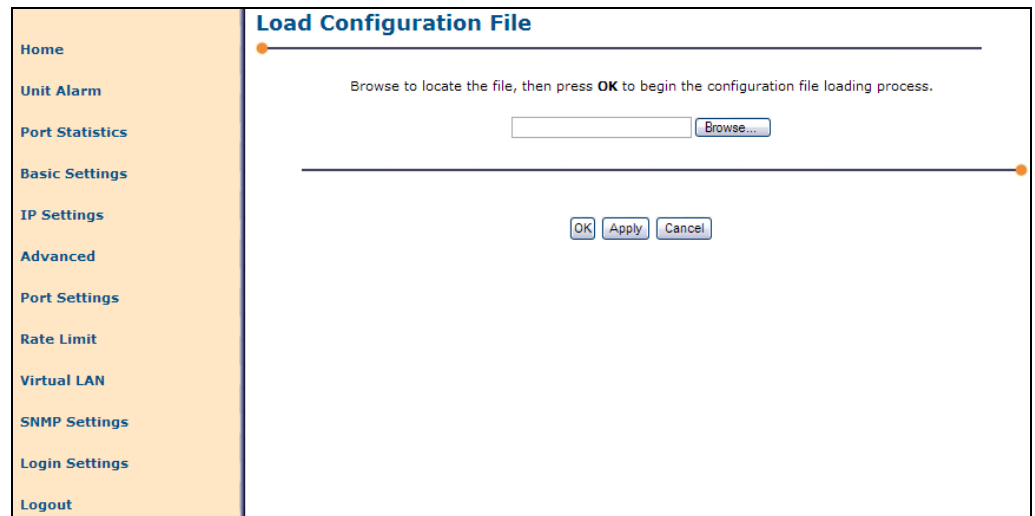

Figure 18 Web Application – Advanced Settings: Load Configuration File

4.7.2.2 Save Configuration File

Save Configuration File: The Save Configuration File feature allows the current TC3240 settings to be saved into a file. The file will be a *.conf file.

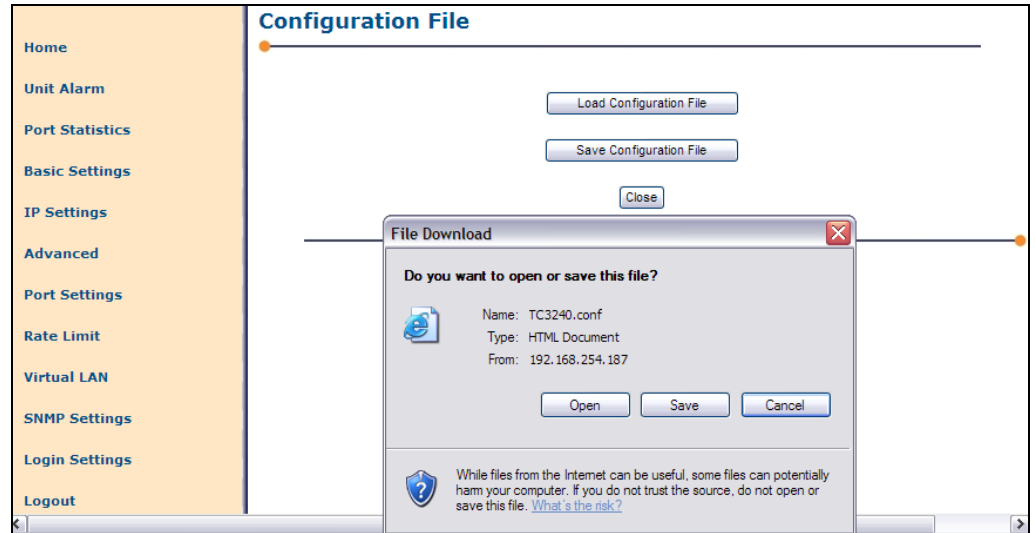

Figure 19 Web Application – Advanced Settings: Save Configuration File

4.7.3 Restart

The Reboot page allows the user to reboot the unit.



Figure 20 Web Application – Advanced Settings: Restart TC3240

4.7.4 Restore Defaults

The Restore Default page allows the user to reset all settings to their original default settings.

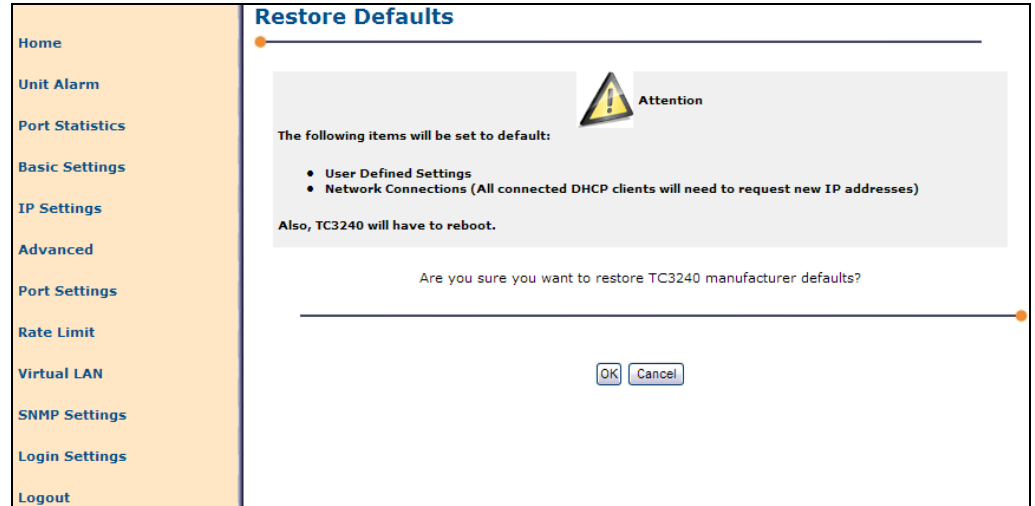

Figure 21 Web Application – Advanced Settings: Restore Default

4.7.5 TC3240 Firmware Upgrade

The Firmware Upgrade page allows the user to upgrade the firmware of the TC3240.



Figure 22 Web Application – Advanced Settings: TC3240 Firmware Upgrade

4.7.6 TC3240 Firmware Upgrade: Upgrade Now

The upgrade page allows the user to choose the file as the upgrade.

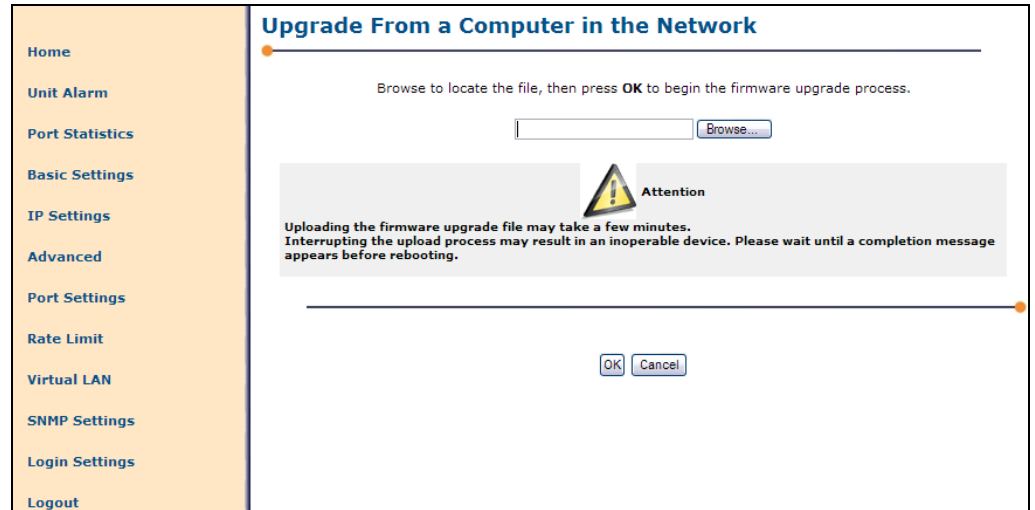

Figure 23 Web Application – Advanced Settings: Upgrade From a Computer in the Network

4.7.7 Date and Time Settings

The Date and Time page displays all time related fields and configurations.

Localization: Displays the current date and time. The current Time Zone is displayed and can be selected from the drop table. To manually configure the time, click on “Clock Set” at the bottom of the page.

Daylight Saving Time: Enable/Disable. Configurable if the Automatic Time Update is disabled.

Automatic Time Update: Enable/Disable. Time Of Day (TOD) allows user to manually set the time. Network Time Protocol (NTP) enables the clock to synchronize with a time server. User can define which time server to use as the default Time Server.

Note: The user needs to correctly set up the Default Gateway and DNS for NTP to synchronize correctly.

Status: Displays the connection status with the chosen Time Server.

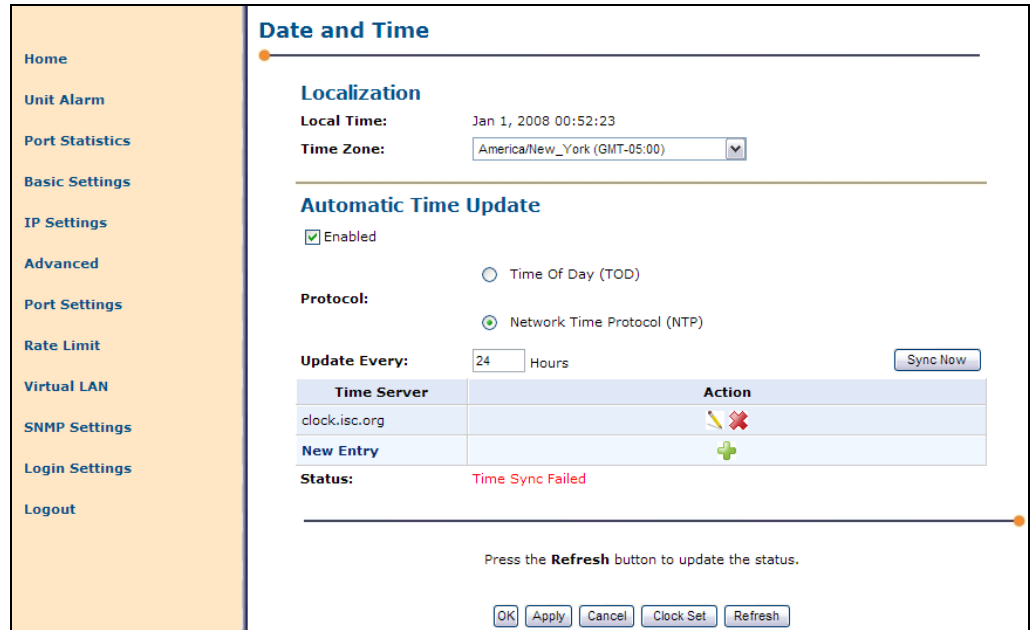

Figure 24 Web Application – Advanced Settings: Date and Time Settings

4.7.7.1 Clock Set

The Clock Set page allows you to manually define the date and time for the TC3240.

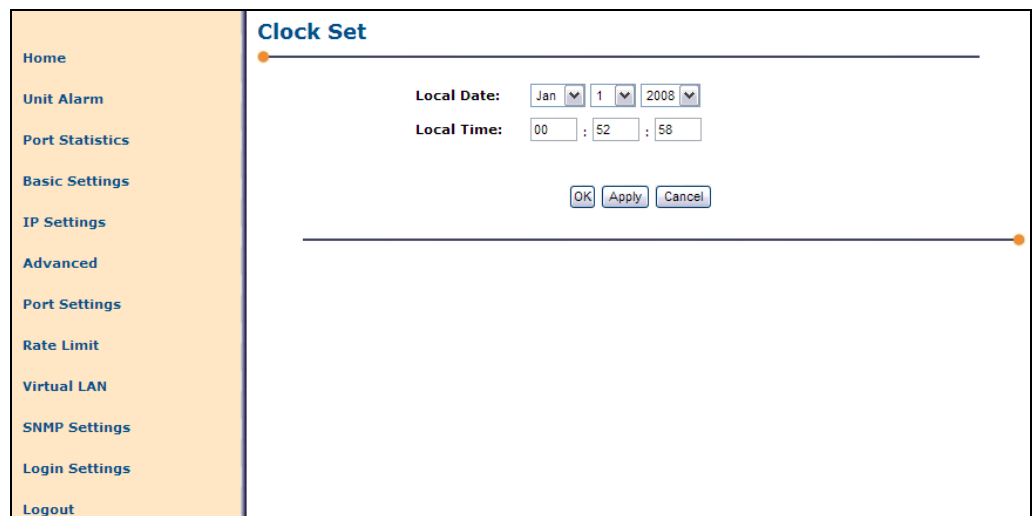

Figure 25 Web Application – Advanced Settings: Clock Set

4.8 Port Settings

TC3240's Ethernet Port Settings displays each Ethernet port's status and allows the configuration of port settings.

Port In-Use: Enable or disable the Ethernet port. Default setting is Enabled.

Speed/Duplex: Choose either 100Mbps Full, 10Mbps Full, 100Mbps Half, 10Mbps Half. Default setting is Auto-Negotiate.

Flow Control: Enable or disable Flow Control; Default is disabled.

Port Label (RJ45 or Fiber): Label the port with desired name to distinguish from other ports, up to 30 characters.

Huge Frame Support: Enable support for Ethernet frames up to 1916 bytes.

Timed Local Loopback: Enable local loopback on an Ethernet port. Range of 1-1440 minutes.

Note: This feature is for advanced users only. Enabling this can have serious consequences on your network. It is intended for user with Ethernet testers.

Home

Unit Alarm

Port Statistics

Basic Settings

IP Settings

Advanced

Port Settings

Rate Limit

Virtual LAN

SNMP Settings

Login Settings

Logout

Port Settings

Port	Port In Use	Speed / Duplex	Flow Control	Current Status
RJ45 #1	Enabled	Auto-Negotiate	Disabled	Not Connected
RJ45 1 Label <input style="width: 80%;" type="text"/> (Max. of 30 characters)				
RJ45 #2	Enabled	Auto-Negotiate	Disabled	100Mbps/Full
RJ45 2 Label <input style="width: 80%;" type="text"/> (Max. of 30 characters)				
RJ45 #3	Enabled	Auto-Negotiate	Disabled	Not Connected
RJ45 3 Label <input style="width: 80%;" type="text"/> (Max. of 30 characters)				
Fiber #1	Enabled	100Mbps/Full	Disabled	Not Connected
Fiber 1 Label <input style="width: 80%;" type="text"/> (Max. of 30 characters)				

Huge Frame Support (up to 1916 Bytes): Enabled

Timed Local Loopback (1 ~ 1440 Minutes)

Port	Local Loopback
RJ45 #1	Enable for <input style="width: 40px;" type="text"/> Minutes <input type="button" value="Proceed"/>
RJ45 #2	Enable for <input style="width: 40px;" type="text"/> Minutes <input type="button" value="Proceed"/>
RJ45 #3	Enable for <input style="width: 40px;" type="text"/> Minutes <input type="button" value="Proceed"/>
Fiber #1	Enable for <input style="width: 40px;" type="text"/> Minutes <input type="button" value="Proceed"/>

Attention

This feature is for advanced users only. Enabling this can have serious consequences on your network. It is intended for user with Ethernet testers.

Figure 26 Web Application – Port Settings

4.8.1 Local Loopback

Home

Unit Alarm

Port Statistics

Basic Settings

IP Settings

Advanced

Port Settings

Rate Limit

Virtual LAN

SNMP Settings

Login Settings

Logout

Port Settings

Port	Port In Use	Speed / Duplex	Flow Control	Current Status
RJ45 #1	Enabled	Auto-Negotiate	Disabled	Not Connected
RJ45 1 Label <input style="width: 80%;" type="text"/> (Max. of 30 characters)				
RJ45 #2	Enabled	Auto-Negotiate	Disabled	100Mbps/Full
RJ45 2 Label <input style="width: 80%;" type="text"/> (Max. of 30 characters)				
RJ45 #3	Enabled	Auto-Negotiate	Disabled	Not Connected
RJ45 3 Label <input style="width: 80%;" type="text"/> (Max. of 30 characters)				
Fiber #1	Enabled	100Mbps/Full	Disabled	Not Connected
Fiber 1 Label <input style="width: 80%;" type="text"/> (Max. of 30 characters)				

Huge Frame Support (up to 1916 Bytes): Enabled

Timed Local Loopback (1 ~ 1440 Minutes)

Port	Local Loopback
RJ45 #1	Enable for <input style="width: 30px;" type="text"/> Minutes <input type="button" value="Proceed"/>
RJ45 #2	Enable for <input style="width: 30px;" type="text"/> Minutes <input type="button" value="Proceed"/>
RJ45 #3	Currently Enabled...
Fiber #1	Currently Enabled...

Attention

This feature is for advanced users only.
Enabling this can have serious consequences on your network.
It is intended for user with Ethernet testers.

Figure 27 Web Application – Port Settings: Local Loopback

4.9 Rate Limit

TC3240's Ethernet Rate Limit feature allows the Network Administrator to regulate the bandwidth of each of the 3 Ethernet ports.

Transmitting and Receiving are separated to allow for extreme flexibility. The port rate limits can be set in increments of 32Kb. If the Network Administrator enters a value that is not a multiple of 32, the TC3240 will automatically round it up to the nearest multiple of 32. For example, if you enter a limit of 100Kbit/sec, then the TC3240 will automatically convert the 100Kbit/sec into 128Kbit/sec.

If you do not want any rate limit imposed on a port, enter '0' for that port's "Norm. Tx Limit" or "Normal Rx Limit" and click "Apply".

Nominal Tx Limit: Here you can define the transmit rate limit. The default value of the rate limit is zero (no limit on the inbound traffic). The rate limit can be set from 32Kbps to up to 100Mbps, in increments of 32Kbps.

Actual Tx Rate: The true transmit rate. If the Normal Tx rate limit is set in any increment of 32Kbps, then the "Actual Tx Rate" field will automatically display the same value. Otherwise, the "Actual Tx. Rate" field will automatically display the next higher increment of the rate limit.

Nominal Rx Limit: Here you can define the receive rate limit. The default value of the rate limit is zero (no limit on the inbound traffic). The rate limit can be set from 32Kbps to up to 100Mbps, in increments of 32Kbps.

Actual Rx Rate: If the receive rate limit is set in any increment of 32Kbps, then the "Actual Rx. Rate" limit field will automatically display the same value. Otherwise, the "Actual Rx. Rate" field will automatically display the next higher increment of the rate limit.

TC COMMUNICATIONS
THE LEADER IN FIBER OPTIC CONNECTIVITY

TC3240 10/100 Base-T Fiber Optic Bridged Media Converter

Rate Limit Settings

Port	Nom. Tx Limit	Act. Tx Rate	Nom. Rx Limit	Act. Rx Rate
RJ45 #1	0 Kbit/sec	Disabled	0 Kbit/sec	Disabled
RJ45 #2	0 Kbit/sec	Disabled	0 Kbit/sec	Disabled
RJ45 #3	0 Kbit/sec	Disabled	0 Kbit/sec	Disabled
Fiber #1	0 Kbit/sec	Disabled	0 Kbit/sec	Disabled

Legend

Nominal (Nom.) Rate : Enter 0 to disable rate limit Actual (Act.) Rate : By increments of 32 Kbits
Tx : Transmit or Egress Rx : Receive or Ingress

Apply

Figure 28 Web Application – Rate Limit Settings

4.10 Virtual LAN

A VLAN is a logical local area network (LAN) that extends beyond a single traditional LAN to a group of LAN segments, given specific software configurations. This first Virtual LAN page displays the member status of each port for various VLAN IDs. You may add/remove any of the 4 ports as a member of a VLAN ID. This first page gives you a general overview of all of the existing Virtual LAN IDs. You can easily make quick changes to multiple VLAN IDs.

Virtual LAN

Static Settings Port Settings

Static VLAN Table

View: Rows 1 ~ 8 Currently: Page #1

Virtual LAN ID	1	2	3	F1	Action
1	M	M	M	M	[Edit] [Remove]
2	M	--	M	--	[Edit] [Remove]
3	M	--	M	M	[Edit] [Remove]
4	M	M	M	M	[Edit] [Remove]
5	M	M	M	M	[Edit] [Remove]
6	M	M	M	M	[Edit] [Remove]
7	M	M	M	M	[Edit] [Remove]
8	M	M	M	M	[Edit] [Remove]

Legend

+ Add new entry [Pencil] Edit existing entry [X] Remove existing entry
M: Member --: Non-Member

Apply

Figure 29 Web Application – Virtual LAN

A Virtual LAN (VLAN) is a logical local area network (LAN) that extends beyond a single traditional LAN to a group of LAN segments, the TC3240 may be implemented in existing infrastructure with VLANs previously configured. To ensure proper compatibility within the node of use, it is important to identify all existing or new VLAN IDs (VID). In the figure above we can see that VIDs 1 through 8 have been identified and membership established for the TC3240 Ports 1 through 3 and Fiber Port 1.

VLAN settings control the action of the Egress Filter for the TC3240 with respect to received and transmitted packets. We will discuss this in more detail as we continue with Virtual LAN settings.

Under the 'Action' column, you may edit the settings of a VLAN ID Entry, such as changing the default VLAN ID of each port.

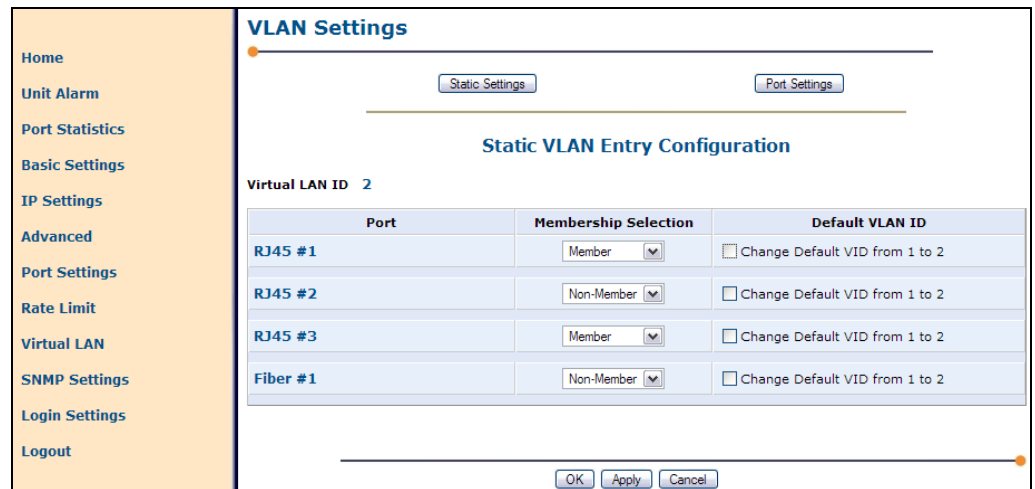

Figure 30 Web Application – VLAN: Edit VLAN

The VLAN settings page provides the administrator with the ability to establish membership for each of the ports with respect to default VID and also allows the administrator to determine the default VID for each port as VID=1 or VID=2. The default configuration for the TC3240 is VID=1. The default VID assigned to each port will determine the action the TC3240 takes with respect to forwarding or dropping received packets. The intent of this feature is to allow the administrator to reduce congestion in LAN nodes. If the packet is not intended for a node which the TC3240 is a member, the administrator will be able to drop or forward packets unchanged as desired. We will continue this discussion moving forward.

4.10.1 VLAN Static Settings

If you create a new VLAN ID, you will need to set it up individually. The VLAN static page allows you to do this.

The screenshot shows the 'Virtual LAN' configuration page. On the left is a navigation menu with options: Home, Unit Alarm, Port Statistics, Basic Settings, IP Settings, Advanced, Port Settings, Rate Limit, Virtual LAN (selected), SNMP Settings, Login Settings, and Logout. The main content area is titled 'Virtual LAN' and contains two tabs: 'Static Settings' (active) and 'Port Settings'. Below the tabs is the 'Static VLAN Table' which is a table with columns: Virtual LAN ID, 1, 2, 3, F1, and Action. The first row shows '1' in the first column, and 'M' in the membership dropdowns for ports 1, 2, 3, and F1. Below the table is an 'Add Static Entry' button with a green plus icon. A legend below the table defines the icons: a green plus for 'Add new entry', a yellow pencil for 'Edit existing entry', and a red X for 'Remove existing entry'. It also defines 'M: Member' and '--: Non-Member'. An 'Apply' button is at the bottom right of the main content area.

Virtual LAN ID	1	2	3	F1	Action
1	M	M	M	M	[Edit]
Add Static Entry					[Add]

Legend

- [+] Add new entry
- [Pencil] Edit existing entry
- [X] Remove existing entry
- M: Member
- : Non-Member

Figure 31 Web Application – VLAN: Static Settings

The VLAN Static Settings page allows the administrator to define "New" VIDs and assign membership for each of the TC3240 ports. In the example above, VID 1 has been defined and each of the ports 1 through 3 and Fiber port 1 have been granted membership.

4.10.2 VLAN Port Settings

VLAN Port Settings allows you to edit the settings of the VLANs from the perspective of each port. Each port's **VLAN Filter** can be enabled/disabled to handle ingress packets, the **Port Type** can be defined to be handle egress packets, and the **Default VLAN ID** of each port can be defined.

For each of the ports RJ45 #1 through #3 and Fiber #1, the administrator will define what action is to be taken for packets received by the TC3240. Referring to the figure below, we see that the VLAN Filter (Ingress) is disabled for Ethernet ports #1, #3 and Fiber #1 and enabled for Ethernet port #2.

Port	VLAN Filter	Port Type	Default VLAN ID (1 - 4094)
RJ45 #1	Disabled	Unmodified	1
RJ45 #2	Enabled	Unmodified	1
RJ45 #3	Disabled	Unmodified	1
Fiber #1	Disabled	Unmodified	1

Figure 32 Web Application – VLAN: Port Settings: Port Type

VLAN Filter defines how the ports receiving ingress packets will process the packets.

When the filter is *enabled* for a port, filtering will perform one of the following actions on ingress packets.

- If the ingress packet does not have a tag, the port will tag the packet with the port's default VID, and the tag will be forwarded within the port's VLAN.
- If the ingress packet's VID tag matches the port's VID membership, the packet will be forwarded within the port's VLAN.
- If the ingress packet's VID tag does not match the port's VID membership but it exists in the Static VLAN Table, the packet will be dropped.
- If the ingress packet's VID tag does not match the port's VID membership and it does not exist in the Static VLAN Table, the packet will be dropped.

When the filter is *disabled* for a port, filtering will only affect packets coming into the port depending on VLAN membership (refer to Section Static VLAN Table). Filtering will perform one of the following actions on ingress packets.

- If the ingress packet does not have a tag, the port will tag the packet with the port's default VID, and the tag will be forwarded within the port's VLAN.
- If the ingress packet's VID tag matches the port's VID membership, the packet will be forwarded within the port's VLAN.
- If the ingress packet's VID tag does not match the port's VID membership but it exists in the Static VLAN Table, the packet will be forwarded within the packet's.
- If the ingress packet's VID tag does not match the port's VID membership and it does not exist in the Static VLAN Table, the packet will be dropped.

For a more complete understanding of the filter behavior, please refer to the table below.

Scenario: Ingress Packet Received	Filter Enabled	Filter Disabled
Un-tagged packets	Tag ingress packets with the port's default VID and forward within the port's VLAN	Tag ingress packets with port's default VID and forward within the port's VLAN
Packets' VID tag matches with the port's VID membership.	Forward ingress packets within port's VLAN(s)	Forward ingress packets within port's VLAN(s)
Packets' VID tag does not match with the port's VID membership but it exists in the Static VLAN Table	Drop ingress packets only	Forward ingress packets to ports within the packet's VLAN
Packets' VID tag does not match with the port's VID membership and does not exist in the Static VLAN Table	Drop ingress packets only	Drop ingress packets only

Table 13 TC3240 Filter Actions

Port Type defines if ingress packets will be transmitted with a tag.

- **Un-Modified:** the port will not modify the packet; it will simply transmit the packet. For example, if an ingress packet is not tagged, it will be transmitted with no tag. If the ingress packet has a tag, then it will be transmitted with the same tag.
- **Egress Un-tagging:** the port will remove an egress packet's tag and then transmit the packet.
- **Egress Tagging:** the port will retain the packets' tag and then transmit the packet.

Scenario: Ingress Packet to be Transmitted	Un-Modified	Egress Un-Tagging	Egress Tagging
Ingress Packet is not tagged	Ingress packet will be transmitted with no tag	Ingress packet will be transmitted with no tag	Ingress packet will be tagged with the ingress port's default VID, and then transmitted
Ingress Packet is tagged	Ingress packet will retain its tag, then transmitted	Ingress packet will be transmitted with no tag	Ingress packet will retain its tag, then transmitted

SNMP Settings

The SNMP (Simple Network Management Protocol) settings consist of two sections: SNMP Access Rights and SNMP Trap. Access Rights are the privileges clients are granted. Traps are alerts that are set off when an error occurs. There is a unique Community String for clients who have Read-Only privileges or Read-Write privileges.

There is a check box to enable SNMP. Next, a Community String may be defined for both users who have Read-Only privileges and users who have Read-Write privileges. Only SNMP clients with the appropriate Community String will be able to access the SNMP features.

The screenshot shows the 'SNMP Settings' page of a web application. On the left is a navigation menu with the following items: Home, Unit Alarm, Port Statistics, Basic Settings, IP Settings, Advanced, Port Settings, Rate Limit, Virtual LAN, SNMP Settings (highlighted), Login Settings, and Logout. The main content area is titled 'SNMP Settings' and contains the following elements:

- Enable SNMP Agent
- Read-Only Community Name:
- Read-Write Community Name:
- Trusted Peer**: A dropdown menu with options: Any Address (selected), Any Address, Specify an IP Address, and Specify a Subnet.
- SNMP Traps**: Enabled

At the bottom of the main content area are three buttons: OK, Apply, and Cancel.

Figure 33 Web Application – SNMP Settings

Next is a check box to enable SNMP Trap. Below that, a Trap Receiving IP Address and the corresponding Community String may be defined. The Trap Receiving IP Address is the IP of the machine that will be receiving the error alerts. The Trap Community String is similar to that of the Access Rights. Only users with the correct Community String may receive traps.

Figure 34 Web Application – SNMP: Traps

4.11 Login Settings

The Login Settings page allows the user to define the security access into the TC3240.

Full Name	User Name	Action
Administrator	admin	
New User		

Name	Description	Members	Group IP Binding	Action
Admin			192.168.254.187	
New Group				

Figure 35 Web Application – Login Settings

4.11.1 Login User Setting

Users: Displays the list of users with access to the TC3240. Users can be added/removed, usernames can be edited, and passwords can be set.

The screenshot shows the 'User Settings' page with a left-hand navigation menu. The menu items are: Home, Unit Alarm, Port Statistics, Basic Settings, IP Settings, Advanced, Port Settings, Rate Limit, Virtual LAN, SNMP Settings, Login Settings, and Logout. The 'Login Settings' item is highlighted. The main content area is titled 'User Settings' and contains a 'General' section with the following fields: 'Full Name:' (empty), 'User Name (case sensitive):' (empty), 'New Password:' (empty), and 'Retype New Password:' (empty). At the bottom of the form are 'OK' and 'Cancel' buttons.

Figure 36 Web Application – Login Settings: Add New User

The screenshot shows the 'User Settings' page with the same navigation menu as Figure 36. The 'Login Settings' item is highlighted. The main content area is titled 'User Settings' and contains a 'General' section with the following fields: 'Full Name:' (Administrator), 'User Name (case sensitive):' (admin), 'New Password:' (masked with dots), and 'Retype New Password:' (masked with dots). At the bottom of the form are 'OK' and 'Cancel' buttons.

Figure 37 Web Application – Login Settings: Edit User

4.11.2 Login Group Setting

This tool can assist you to organize multiple TC3240 users. A group can be set up to include desired members. This simplifies the user settings by allowing you simply add multiple users into a group and only defining the group settings.

A key security feature of the TC3240 is Group IP Binding. Similar to the idea of IP Aliases, this is the IP address that a group can use to access the TC3240. This allows groups to access the TC3240 without knowing the IP address that the network administrator uses to access the TC3240.

The screenshot shows the 'Group Settings' web application interface. On the left is a vertical navigation menu with the following items: Home, Unit Alarm, Port Statistics, Basic Settings, IP Settings, Advanced, Port Settings, Rate Limit, Virtual LAN, SNMP Settings, Login Settings, and Logout. The 'Login Settings' item is highlighted. The main content area is titled 'Group Settings' and contains the following sections:

- Name:** A text input field containing the word 'Group'.
- Description:** An empty text input field.
- Group Members:** A section with a red 'X' icon and the text 'Administrator'.
- Group IP Binding:** A section with a dropdown menu labeled 'Group IP Binding:'. The dropdown is open, showing three options: 'Alias 0: 123.123.123.123', 'No Binding', and 'Mgmt. IP: 192.168.254.187'. The first option is selected.
- Group Page Access:** A section with a list of checkboxes for various settings: Unit Alarm, Port Statistics, Basic Settings, IP Settings, Advanced, Port Settings, Rate Limit, Virtual LAN, SNMP Settings, and Login Settings. All checkboxes are currently unchecked.

At the bottom right of the main content area, there are two buttons: 'OK' and 'Cancel'.

Figure 38 Web Application – Login Settings: Add New Group

An additional security feature is defining the group page access. Here you can define which pages/links of the TC3240 that each group can access.

Figure 39 Web Application – Login Settings: Edit Group

4.12 Logout

The Logout link on the left column will exit the user from the TC3240 Web Management. It will return the user to the Login page.

Figure 40 Web Application – Log Out

5 Management via Console/Telnet

5.1 Console/Telnet Management

The console management can be accessed through the RS-232 port on the rear panel (DB9 connector) using a PC and terminal software (Hyper Terminal).

Attention: If you are unsure about the settings, contact your network administrator. Improper settings may result in disruption of the existing network.

Once you connect to the TC3240, you will be prompted to enter a Username and Password. Both the user name and password are "admin".

There are a couple of key functions that are essential to be familiar with.

- help:** At any given point, this will assist user with instructions of how to use functions.
- tab key:** This will help fill out a partially entered function. For example, if the User typed only "he" and then pressed the tab key, the console will automatically complete the word into "help".
- exit:** This allows the user to leave the directory he is presently in.

The console port allows the user either to use a local VT-100 terminal or use a remote VT-100 terminal via modem for system configuration, diagnostics, polling status reports, etc. The console port Baud rate, data bit length, stop bit length, and parity bit length.

5.1.1 Initial IP setting using the Console

1. Connect the computer to the TC3240 rear panel DB9 connector via a DB9 serial cable.
2. Power up the TC3240 unit.
3. Open the HyperTerminal of your computer and under properties select the following settings: 9600 Baud, 8 data bits, No parity, 1 stop bit, and None for flow control. See below.

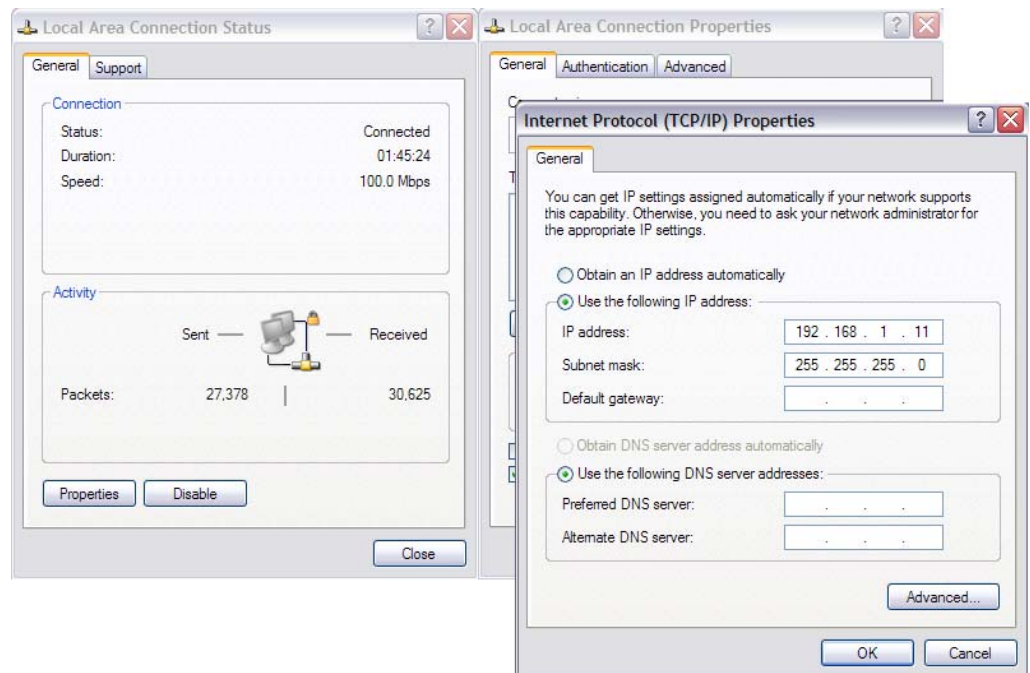

Figure 41 Terminal Settings - Console Port Configuration

4. Click "OK" or press Enter, when done.
5. Press the "Enter" key until you see a "Username" prompt.
6. The username is "admin", and the password is "admin".
7. When password has been entered correctly, you will a TC3240 prompt.
8. At this point, you can continue to enter all the settings.
9. To set the IP, enter `ip_ip_set 192.168.1.50` and press "Enter."
10. To set the netmask, enter `ip_netmask_set 255.255.255.0` and press "Enter."
11. To set the gateway, enter `ip_gateway_set 192.168.1.111` and press "Enter."
12. To set the username, enter `user_username_set John123`, and press "Enter."
13. To set the password, enter `user_password_set 123456`, and press "Enter."

5.1.2 Console Help

The console "help" and "help set" commands will assist you with information about various command descriptions as shown below.

ip_ip_set:	Set Unit's IP Address.	E.g. ip_ip_set 192.168.1.50
ip_netmask_set:	Set Unit's Netmask.	E.g. ip_netmask_set 255.255.255.0
ip_gateway_set:	Set Unit's Gateway IP	E.g. ip_gateway_set 192.168.1.111
user_username_set:	Set login username	E.g. user_username_set John123
user_password_set:	Set login password	E.g. user_password_set 123456
restore_default:	Set unit to factory default	
ip_mac_get:	Get unit's Mac address	

Note: The default "timeout" value for console setting is two minutes.

5.1.3 Telnet Settings

You may also use Telnet to set the IP configuration, username, and password. You may use the Telnet option from the network or local connection using a PC connected by RS232 Serial port connection.

To access the unit via Telnet open a command window or terminal. Type the command *Telnet <ip address>*
This will return the username request.

Note: in our example the TC3240 that we are connected to has been assigned ip address 192.168.1.105 - this will vary with your initial configuration typically 192.168.1.1 as with most standard router/switch devices).

Type the default username *<admin>*
This will return the password request.

Type the default password *<admin>*
You now have established a telnet session with the TC3240

With a Telnet Session established, you may review available options and commands by accessing help.

To access help, Type *<help>*
This will return the default help menu as shown below.

```

Telnet 192.168.1.105
Returned 1
TC3240> help
Error: help should be called with 1 argument
help  Commands Help

Usage:
    help <"all" | category | command>
where:
    help all - show all available commands
    help <category> - show commands in a certain category
    help <command> - show detailed help for a specific command

Available help Categories
help unit_alarm - show help about TC3240 Unit Alarm
help port_statistics - show help about Port Statistics
help basic_settings - show help about Basic Settings
help ip_settings - show help about IP Settings
help adv_settings - show help about Advanced Settings
help port_settings - show help about Port Settings
help rate_limit - show help about Rate Limit Control
help vlan - show help about Virtual LAN
help login_settings - show help about User Login Settings
help update - show help about Remote upgrade commands

Returned -1

```

Figure 42 Telnet Help Menu

Note: To access any of the help options, syntax is case and context sensitive. Type commands exactly as they appear in the menu.

Note: The Telnet default "timeout" is two minutes.

5.1.3.1 Unit Alarms

You may request unit alarm status for the TC3240 by typing the command `<help unit_alarm>`. This will return the unit alarm command subset as shown below.

```

Telnet 192.168.1.105
Bad command
Returned 1
TC3240> help unit_alarm

Command Category unit_alarm - TC3240 Unit Alarm
alarm_status      Check if unit alarm status is on
alarm_enable_get  Check if unit alarm setting is enabled
alarm_enable_set  Enable/disable unit alarm setting
dry_contact_get   Check if dry contact is enabled
dry_contact_set   Enable/disable dry contact
alarm_buzzer_get  Check if alarm buzzer is enabled
alarm_buzzer_set  Enable/disable alarm buzzer
alarm_criteria    Show a list of alarm criteria that will trigger the unit
alarm             alarm
rj45_1_set        Enable/disable RJ45 Port 1 alarm trigger
rj45_2_set        Enable/disable RJ45 Port 2 alarm trigger
rj45_3_set        Enable/disable RJ45 Port 3 alarm trigger
fiber_1_set       Enable/disable Fiber Port 1 alarm trigger
lpbk_set          Enable/disable Loopback alarm trigger
alarm_clear       Clear the unit alarm
alarm_cut_off     Activate the alarm cut-off

Returned 0
TC3240>

```

Figure 43 Telnet Unit Alarm Menu

5.1.3.2 Port Statistics

You may request unit port statistics for the TC3240 by typing the command `<help port_statistics>`. This will return the port statistics command subset as shown below.

```

CA Telnet 192.168.1.105
help ip_settings - show help about IP Settings
help adv_settings - show help about Advanced Settings
help port_settings - show help about Port Settings
help rate_limit - show help about Rate Limit Control
help vlan - show help about Virtual LAN
help login_settings - show help about User Login Settings
help update - show help about Remote upgrade commands

Returned -1
TC3240> help port_statistics

Command Category port_statistics - Port Statistics
stat_period_get Retrieve history statistics save rate in minutes
stat_period_set Set history statistics save rate in minutes
stat_current_get Retrieve current statistics of individual RJ45/Fiber port
stat_hist_row_get Retrieve history statistics of a specific row of
individual RJ45/Fiber port
stat_hist_rows_get Retrieve history statistics between two specific rows of
RJ45/Fiber individual port
stat_hist_clear Clear history statistics of individual RJ45/Fiber port
stat_event_get Retrieve event statistics of individual RJ45/Fiber port
stat_event_clear Clear event statistics of individual RJ45/Fiber port

Returned 0
TC3240>

```

Figure 44 Telnet Port Statistics Menu

5.1.3.3 Basic Settings

You may request unit basic settings for the TC3240 by typing the command `<help basic_settings>`. This will return the basic settings command subset as shown below.

```

CA Telnet 192.168.1.105
help rate_limit - show help about Rate Limit Control
help vlan - show help about Virtual LAN
help login_settings - show help about User Login Settings
help update - show help about Remote upgrade commands

Returned -1
TC3240> help basic_settings

Command Category basic_settings - Basic Settings
system_get Retrieve basic information of the system
system_name_get Retrieve the name of the system
system_name_set Set the name of the system
system_loc_get Retrieve the location of the system
system_loc_set Specify where the system is located
system_contact_get Retrieve contact information of the system
system_contact_set Set contact information of the system
system_desc1_get Retrieve system description #1
system_desc1_set Set system description #1
system_desc2_get Retrieve system description #2
system_desc2_set Set system description #2
system_desc3_get Retrieve system description #3
system_desc3_set Set system description #3

Returned 0
TC3240>

```

Figure 45 Telnet Basic Settings Menu

5.1.3.4 IP Settings

You may request unit ip settings for the TC3240 by typing the command `<help ip_settings>`. This will return the ip settings command subset as shown below.

```

c:\ Telnet 192.168.1.105
help port_statistics - show help about Port Statistics
help basic_settings - show help about Basic Settings
help ip_settings - show help about IP Settings
help adv_settings - show help about Advanced Settings
help port_settings - show help about Port Settings
help rate_limit - show help about Rate Limit Control
help vlan - show help about Virtual LAN
help login_settings - show help about User Login Settings
help update - show help about Remote upgrade commands

Returned -1
TC3240>
TC3240> help ip_settings

Command Category ip_settings - IP Settings
ip_ip_get          Get current IP address
ip_ip_set          Set current IP address
ip_netmask_get     Get current subnet mask
ip_netmask_set     Set current subnet mask
ip_gateway_get     Get current default gateway
ip_gateway_set     Set current default gateway
ip_mac_get         Get current MAC address

Returned 0
TC3240>

```

Figure 46 Telnet IP Settings Menu

5.1.3.5 Advanced Settings

You may request unit advanced settings for the TC3240 by typing the command `<help adv_settings>`. This will return the advanced settings command subset as shown below.

```

user_entry_password_set
user_entry_group_set
user_entry_print
user_entry_print_all
group_entry_add
group_entry_del
group_entry_groupname_set
group_entry_description_get
group_entry_description_set
group_entry_print
group_entry_print_all
help
rmt update
TC3240> help adv_settings

Command Category adv_settings - Advanced Settings
conf_load          Load configuration file
reboot             Reboot the system
restore_default    Restore default configuration
watchdog_get       Retrieve the Watchdog counter of the unit
about_tc3240       Retrieve the general information of the unit

Returned 0
TC3240>

```

Figure 47 Telnet Advanced Settings Menu

5.1.3.6 Port Settings

You may request unit port settings for the TC3240 by typing the command `<help port_settings>`. This will return the port settings command subset as shown below.

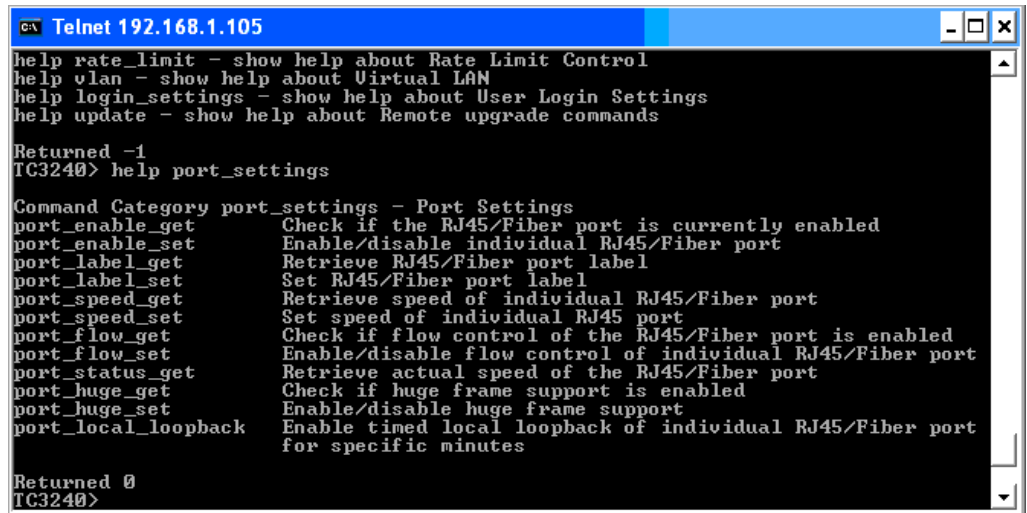

```

C:\ Telnet 192.168.1.105
help rate_limit - show help about Rate Limit Control
help vlan - show help about Virtual LAN
help login_settings - show help about User Login Settings
help update - show help about Remote upgrade commands

Returned -1
TC3240> help port_settings

Command Category port_settings - Port Settings
port_enable_get      Check if the RJ45/Fiber port is currently enabled
port_enable_set      Enable/disable individual RJ45/Fiber port
port_label_get       Retrieve RJ45/Fiber port label
port_label_set       Set RJ45/Fiber port label
port_speed_get       Retrieve speed of individual RJ45/Fiber port
port_speed_set       Set speed of individual RJ45 port
port_flow_get        Check if flow control of the RJ45/Fiber port is enabled
port_flow_set        Enable/disable flow control of individual RJ45/Fiber port
port_status_get      Retrieve actual speed of the RJ45/Fiber port
port_huge_get        Check if huge frame support is enabled
port_huge_set        Enable/disable huge frame support
port_local_loopback  Enable timed local loopback of individual RJ45/Fiber port
                    for specific minutes

Returned 0
TC3240>
```

Figure 48 Telnet Port Settings Menu

5.1.3.7 Rate Limit

You may request unit rate limit for the TC3240 by typing the command `<help rate_limit>`. This will return the rate limit command subset as shown below.

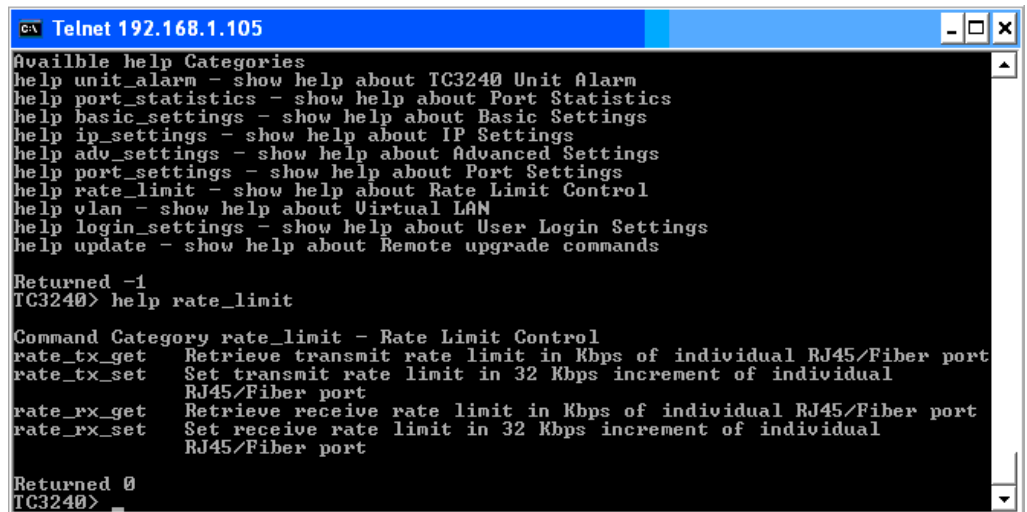

```

C:\ Telnet 192.168.1.105
Available help Categories
help unit_alarm - show help about TC3240 Unit Alarm
help port_statistics - show help about Port Statistics
help basic_settings - show help about Basic Settings
help ip_settings - show help about IP Settings
help adv_settings - show help about Advanced Settings
help port_settings - show help about Port Settings
help rate_limit - show help about Rate Limit Control
help vlan - show help about Virtual LAN
help login_settings - show help about User Login Settings
help update - show help about Remote upgrade commands

Returned -1
TC3240> help rate_limit

Command Category rate_limit - Rate Limit Control
rate_tx_get          Retrieve transmit rate limit in Kbps of individual RJ45/Fiber port
rate_tx_set          Set transmit rate limit in 32 Kbps increment of individual
                    RJ45/Fiber port
rate_rx_get          Retrieve receive rate limit in Kbps of individual RJ45/Fiber port
rate_rx_set          Set receive rate limit in 32 Kbps increment of individual
                    RJ45/Fiber port

Returned 0
TC3240>
```

Figure 49 Telnet Rate Limit Menu

5.1.3.8 VLAN

You may request unit virtual LAN settings for the TC3240 by typing the command

<help vlan>. This will return the VLAN command subset as shown below.

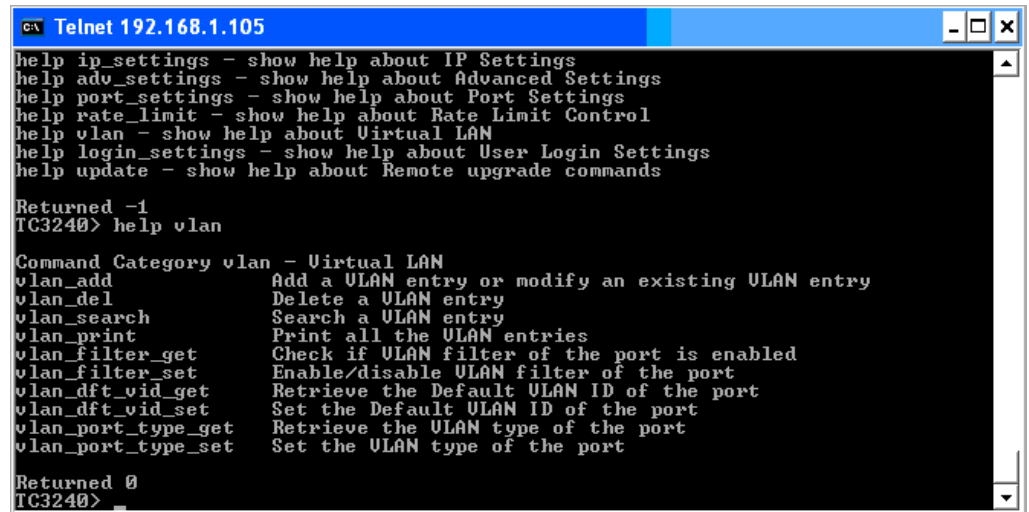

```
ca Telnet 192.168.1.105
help ip_settings - show help about IP Settings
help adv_settings - show help about Advanced Settings
help port_settings - show help about Port Settings
help rate_limit - show help about Rate Limit Control
help vlan - show help about Virtual LAN
help login_settings - show help about User Login Settings
help update - show help about Remote upgrade commands

Returned -1
TC3240> help vlan

Command Category vlan - Virtual LAN
vlan_add      Add a VLAN entry or modify an existing VLAN entry
vlan_del      Delete a VLAN entry
vlan_search   Search a VLAN entry
vlan_print    Print all the VLAN entries
vlan_filter_get Check if VLAN filter of the port is enabled
vlan_filter_set Enable/disable VLAN filter of the port
vlan_dft_vid_get Retrieve the Default VLAN ID of the port
vlan_dft_vid_set Set the Default VLAN ID of the port
vlan_port_type_get Retrieve the VLAN type of the port
vlan_port_type_set Set the VLAN type of the port

Returned 0
TC3240>
```

Figure 50 Telnet VLAN Menu

5.1.3.9 Login Settings

You may request unit login settings for the TC3240 by typing the command <help login_settings>. This will return the login command subset as shown below.

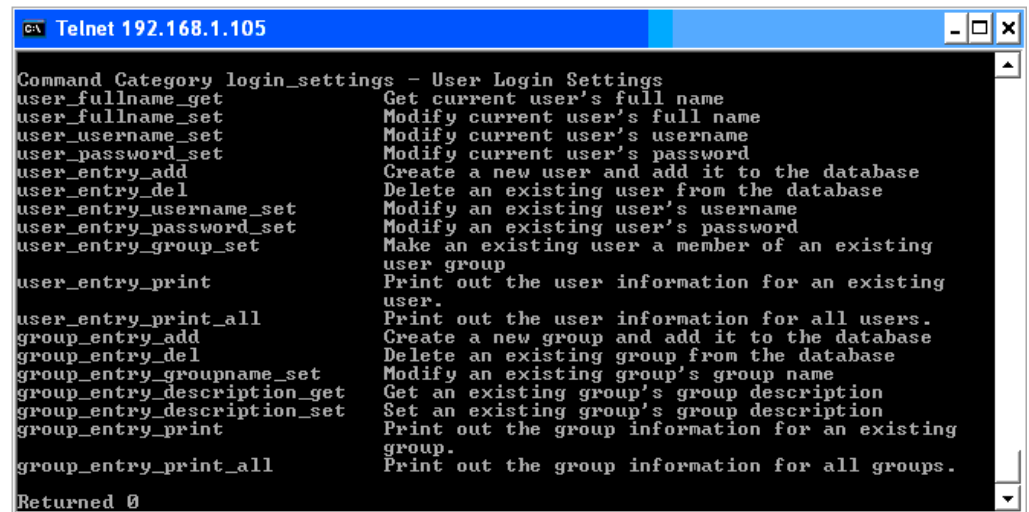

```
ca Telnet 192.168.1.105

Command Category login_settings - User Login Settings
user_fullname_get Get current user's full name
user_fullname_set Modify current user's full name
user_username_set Modify current user's username
user_password_set Modify current user's password
user_entry_add    Create a new user and add it to the database
user_entry_del    Delete an existing user from the database
user_entry_username_set Modify an existing user's username
user_entry_password_set Modify an existing user's password
user_entry_group_set Make an existing user a member of an existing user group
user_entry_print  Print out the user information for an existing user.
user_entry_print_all Print out the user information for all users.
group_entry_add   Create a new group and add it to the database
group_entry_del   Delete an existing group from the database
group_entry_groupname_set Modify an existing group's group name
group_entry_description_get Get an existing group's group description
group_entry_description_set Set an existing group's group description
group_entry_print Print out the group information for an existing group.
group_entry_print_all Print out the group information for all groups.

Returned 0
```

Figure 51 Telnet Login Settings Menu

5.1.3.10 Update Settings

You may request remote update options for the TC3240 by typing the command <help update>. This will return the update command subset as shown below.

```
cx Telnet 192.168.1.105
where:
  help all - show all available commands
  help <category> - show commands in a certain category
  help <command> - show detailed help for a specific command

Available help Categories
help unit_alarm - show help about TC3240 Unit Alarm
help port_statistics - show help about Port Statistics
help basic_settings - show help about Basic Settings
help ip_settings - show help about IP Settings
help adv_settings - show help about Advanced Settings
help port_settings - show help about Port Settings
help rate_limit - show help about Rate Limit Control
help vlan - show help about Virtual LAN
help login_settings - show help about User Login Settings
help update - show help about Remote upgrade commands

Returned -1
TC3240> help update

Command Category update - Remote upgrade commands
rmt_update Remotely upgrade TC3240

Returned 0
TC3240>
```

Figure 52 Telnet Remote Update Menu

6 SNMP Management

6.1 SNMP Management

The TC3240 comes standard with built in SNMP Agent. Contact TC Communication Technical Support to get a copy of the MIB file. TC Communications MIB file can be run on any 3rd party SNMP Management Software. Trap IP must be defined by the user and the MIB file compiled by SNMP Manager software prior to the trap operation.

6.1.1 SNMP Third Party Management Software

The figure below shows an example of the TC3240 SNMP being managed with a third party vendor software.

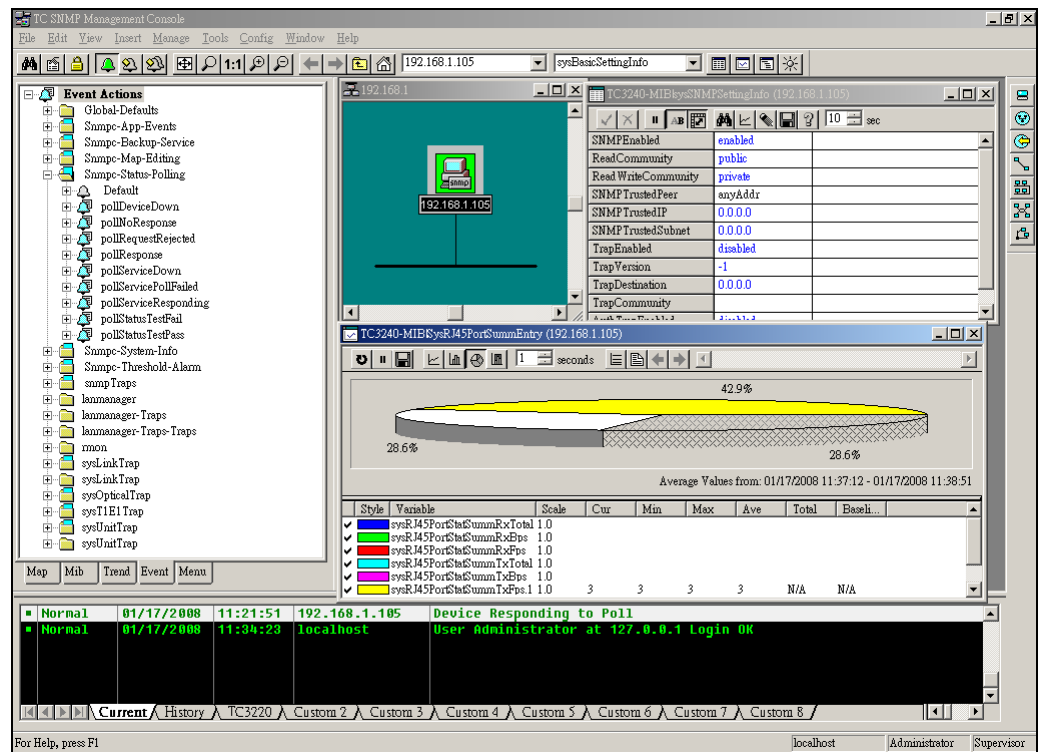

Figure 53 Third Party SNMP Manager

6.1.2 SNMP Trap Management

The figure below shows examples of SNMP Traps sent from the TC3240 to the SNMP Manager Software on the administrators desktop.

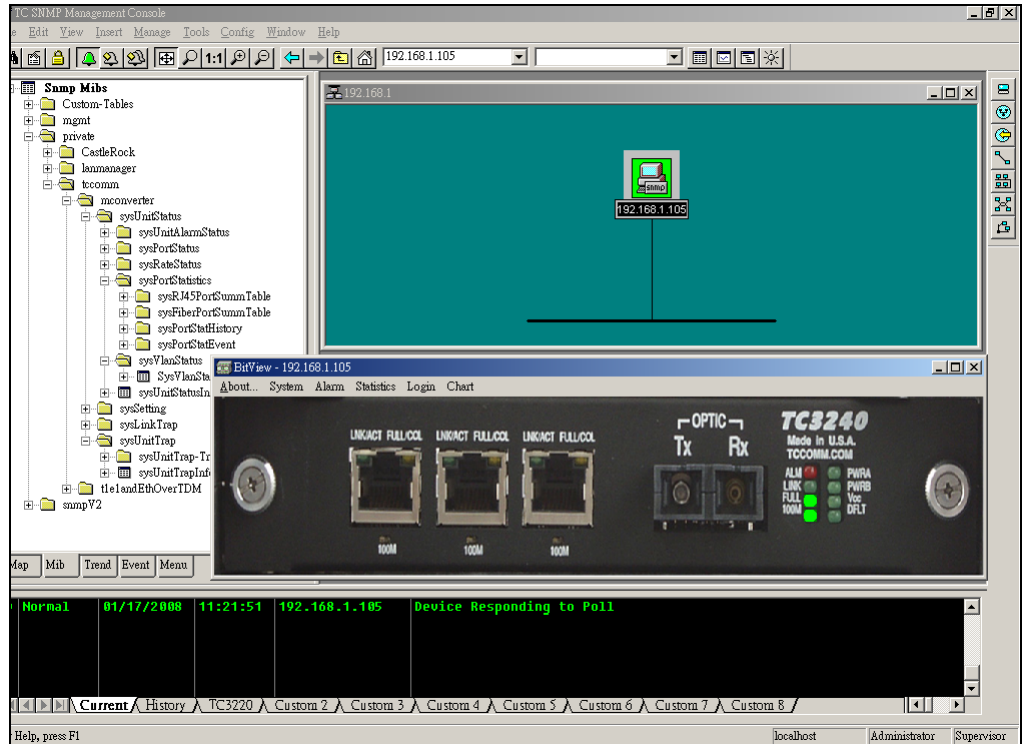

Figure 54 SNMP Trap Display

7 Troubleshooting/Maintenance and Testing

7.1 General

Alarm conditions occur whenever an optical or electrical problem (fault conditions) is detected by the TC3240.

Electrical:

The copper ports' LINK/ACT is solid green when the port is connected and a connection is detected, and it will flash when activity is present. The FULL/COL will be lit depending on the incoming signal. If the Ethernet signal is 100Mbps and full duplex, the 100M LED will light solid. If the Ethernet connection is not 100Mbps or if it is half duplex, both FULL/COL and 100M will be off.

Optics:

If an Ethernet signal is detected, the LINK LED will light solid. If the signal is 100Mbps Full Duplex, both the FULL and 100M will light solid. Otherwise, they will be off.

The Ethernet LINK/ACT is solid green when port is connected and link signal IS present and will flash when activity present. The FULL/COL will be lit depending on the incoming signal. (If the Ethernet signal is 10/100Mbps and full duplex, the FULL/COL and 100M LEDs should be lit). If the Ethernet connection is not 100Mbps or if it is half duplex, then both FULL/COL AND 100M will be off.

7.1.1 All LEDs are "OFF"

If no LEDs are lit on the unit, check the power supply, connector plug, and/or the power source. If the problem persists, contact the Technical Support Department at TC Communications, Inc.

Warranty Breach Warning Note:

Do not, for any reason, open the TC3240 unit. If you suspect of any problems with the unit, contact the Technical Support Department at TC Communications, Inc. for assistance. If the unit is opened without prior authorization from TCCI, it will result in the loss of warranty.

7.1.2 "Alarm Condition" - ALM LED on the front panel

When an alarm condition is detected, the "ALARM" LED will light up red, and the dry contact relay will close or open depending which contact you use. By default, the following fault conditions will cause the alarm to be triggered:

1. Optic signal lost from "Rx-A."
2. Optic signal is marginal, which causes invalid data packets to be received; the "Rx-A" LED will be flashing.
3. The remote unit lost power.

7.1.3 Optic Cable Types

Conventionally, fiber optic cable with yellow-colored insulation is used for Single Mode applications; gray or orange-colored insulated cable is for Multimode use. If Multimode cable is used in a Single Mode application, the test results could be erroneous and confusing.

7.1.4 Calculating the loss on the Fiber

The fiber optic link and/or connectors are frequently the source of various problems. Check out the connectors and the integrity of the link first. Ideally, the link should be calibrated for total loss after the installation has been completed. This will accomplish two things: (1) it will verify that the total loss of the link is within the loss budget of the device and (2) it will provide a benchmark for future testing. For example, a system that has been tested as having 6dB total loss when installed and suddenly tests out as having a loss of 10dB probably has a connector or link problem.

These are the reference values we use to calculate the loss on the fiber:		
Multimode 1310nm	:	2 dB loss per km on 62.5/125µm cable*
Single Mode 1310nm	:	0.5 dB loss per km on 9/125µm cable*
Single Mode 1550nm	:	0.25 dB loss per km on 9/125µm cable*

**Reference only. TCCI recommends an OTDR reading be used to determine actual link loss.*

Figure 55 Reference for Calculating Fiber Loss

8 Return Policy and Warranty

8.1 Return Policy

To return a product, you must first obtain a Return Material Authorization number from the Customer Service Department. If the product's warranty has expired, you will need to provide a purchase order to authorize the repair. When returning a product for a suspected failure, please provide a description of the problem & any results of diagnostic tests that have been conducted.

8.2 Warranty

Damages by lightning or power surges are not covered under this warranty.

All products manufactured by TC Communications, Inc. come with a five year (beginning 1-1-02) warranty. TC Communications, Inc. warrants to the Buyer that all goods sold will perform in accordance with the applicable data sheets, drawings or written specifications. It also warrants that, at the time of sale, the goods will be free from defects in material or workmanship. This warranty shall apply for a period of five years from the date of shipment, unless goods have been subject to misuse, neglect, altered or destroyed serial number labels, accidents (damages caused in whole or in part to accident, lightning, power surge, floods, fires, earthquakes, natural disasters, or Acts of God.), improper installation or maintenance, or alteration or repair by anyone other than Seller or its authorized representative.

Buyer should notify TC Communications, Inc. promptly in writing of any claim based upon warranty, and TC Communications, Inc., at its option, may first inspect such goods at the premises of the Buyer, or may give written authorization to Buyer to return the goods to TC Communications, Inc., transportation charges prepaid, for examination by TC Communications, Inc. Buyer shall bear the risk of loss until all goods authorized to be returned are delivered to TC Communications, Inc. TC Communications, Inc. shall not be liable for any inspection, packing or labor costs in connection with the return of goods.

In the event that TC Communications, Inc. breaches its obligation of warranty, the sole and exclusive remedy of the Buyer is limited to replacement, repair or credit of the purchase price, at TC Communications, Inc.'s option.

To return a product, you must first obtain a Return Material Authorization (RMA) number and RMA form from the Customer Service Department. If the product's warranty has expired, you will need to provide a purchase order to authorize the repair. When returning a product for a suspected failure, please fill out RMA form provided with a description of the problem(s) and any results of diagnostic tests that have been conducted. The shipping expense to TC Communications should be prepaid. The product should be properly packaged and insured. After the product is repaired, TC Communications will ship the product back to the shipper at TC's cost to U.S. domestic destinations. (Foreign customers are responsible for all shipping costs, duties and taxes [both ways]. We will reject any packages with airway bill indicating TC communications is responsible for Duties and Taxes. To avoid Customs Duties and Taxes, please include proper documents indicating the product(s) are returned for repair/retest).

Appendix A - Command Line Interface

Terminal Operation

This appendix provides an overview of the command-line interface commands and features for configuring and troubleshooting the TC3240 Multiplexer. The TC3240 provides configuration and test capabilities through the console port or Telnet connection. A VT-100 type terminal can be used to connect to the console port on the front of the TC3240, or the user can Telnet through an Ethernet connection.

The TC3240 CLI has a hierarchy of multiple modes. The commands available to you depend on which mode you are currently in. Common commands include **help**, **exit**, and the **tab key**.

Help -	show all available help commands within this menu
Exit -	exit the current mode
Tab Key	1) lists all elements within mode. 2) completes a partially entered command.

Appendix B - Important Notice

Important Notice

Important Notice !!!

Please read carefully

If you need to return our products for any reason.....

TC Communications, Inc. is not responsible for items lost or damaged during shipments back to our facilities. It is the customer's responsibility to ensure proper packaging before shipment.

TC Communications recommends **retaining the original box and packaging material** to ensure proper equipment protection before shipment.

If you need assistance or have additional questions, please contact our Technical Support Department at (949) 852-1973.