

The Leading Supplier of Industrial Fiber Optic Communication Platforms



Product Guide



About TC Communications



Vision

Strive to become the Most Reliable Designer & Manufacturer for Optical Communication Equipment

Who Is TC Communications?

Since its inception in 1992, TC Communications has focused on designing and manufacturing the most versatile and reliable fiber optic communication products possible to meet the rigorous requirements of industrial, military, government and commercial customers all over the world.

A decade and one-half later, more than 10,000 satisfied customers are true testaments to the outstanding performance of TC Communications as one of the world's leading fiber optic communication equipment manufacturers.

After several relocations due to continuous growth, TC Communications moved into its current 50,000 square foot corporate headquarters in Irvine, California in November 2006. This facility features a massive production and test area, including a spacious walk-in climatic chamber.

One hundred percent of TC's products are cycled and tested live in this environmental chamber to insure that components are functioning normally before shipment. We at TC Communications truly believe in the adage of "One more hour of thorough factory testing translates into years of problem-free operation in the field."

TC Communications takes pride in being the "right" vendor for your application. Customers are guaranteed high quality products and timely, courteous and professional Service.

Mission

- Excel Through Continuous Improvement
- Compete Through Best Price Performance Value
- Treasure Partnerships through Commitment, Execution & Quality

Technological Evolution

With extensive analog and digital design capabilities in TDM and IP technologies, TC Communication's product lines cover the entire spectrum of fiber optic communications. These products address a wide range of user needs, from simple 1-channel fiber optic modems for various Serial, Ethernet or Voice interfaces, to the most sophisticated multi-channel, Dual Master, Self-Healing, Redundant fiber ring multiplexers; and, the latest flagship product family, the JumboSwitch® series, an Industrial Hardened Gigabit Ethernet Modular Switch.

The JumboSwitch® product family possesses the capability to connect all popular interfaces used in today's automation communication networks, with easily managed add-drop capabilities, onto a redundant fiber optic Gigabit Ethernet backbone. You will find it to be the most simple and graceful solution currently available to solve the complex communication problems network design engineers face today.

After years of improvements, TC Communications now features more than 50 different industrial hardened fiber optic communication products deployed successfully through out the world.

About TC Communications



These products offer customers a wide selection of fiber optic solutions and can be categorized into the following lines :

- **Fiber Optic Ethernet Switches & Media Converters**
- **Fiber Optic Modems & Multiplexers**
- **Fast Recovery Self-Healing Redundant Fiber Optic Multiplexers/Switches**
- **Telephone/Leased Line/Intercom Extenders**
- **Various Mode Converters from Low to High Bit Rates**
- **Industrial Gigabit Ethernet Modular Switch Series**

Markets

TC Communications' products have been installed and commissioned worldwide, from the frigid northern regions of Canada to the searing heat of the Arabian deserts and southern-most provinces in South Africa, in the following arenas:

- **Utilities, Oil Refineries, Pipelines & Water Treatment Plants**
- **Transportation (Railroads, Metro Rapid Transits, Bridges, etc.)**
- **Telecoms & Service Providers**
- **Aerospace, Government & Military Bases**
- **College & University Campuses**

Quality

TC is committed to designing and manufacturing high quality products. As evidence of this commitment, TC is certified to ISO 9001:2000. Its Engineering and Production departments feature extensive on-site testing equipment to verify that all products exceed pertinent industry and environmental specifications.



All TC products are designed with the user in mind; that is, easy installation, self-testing, low power consumption, low component counts, long MTBF's and replaceable EPROM's for changing or upgrading.

Every TC product passes through "live operating temperature" testing (versus randomly selected products for statistical testing) before it is shipped. Each unit is connected to an operating BER tester to ensure error-free operation while the temperature chamber cycles from -40°C to 80°C during the 24 hour testing period.



JumboSwitch®

Industrial Gigabit Ethernet Modular Switch

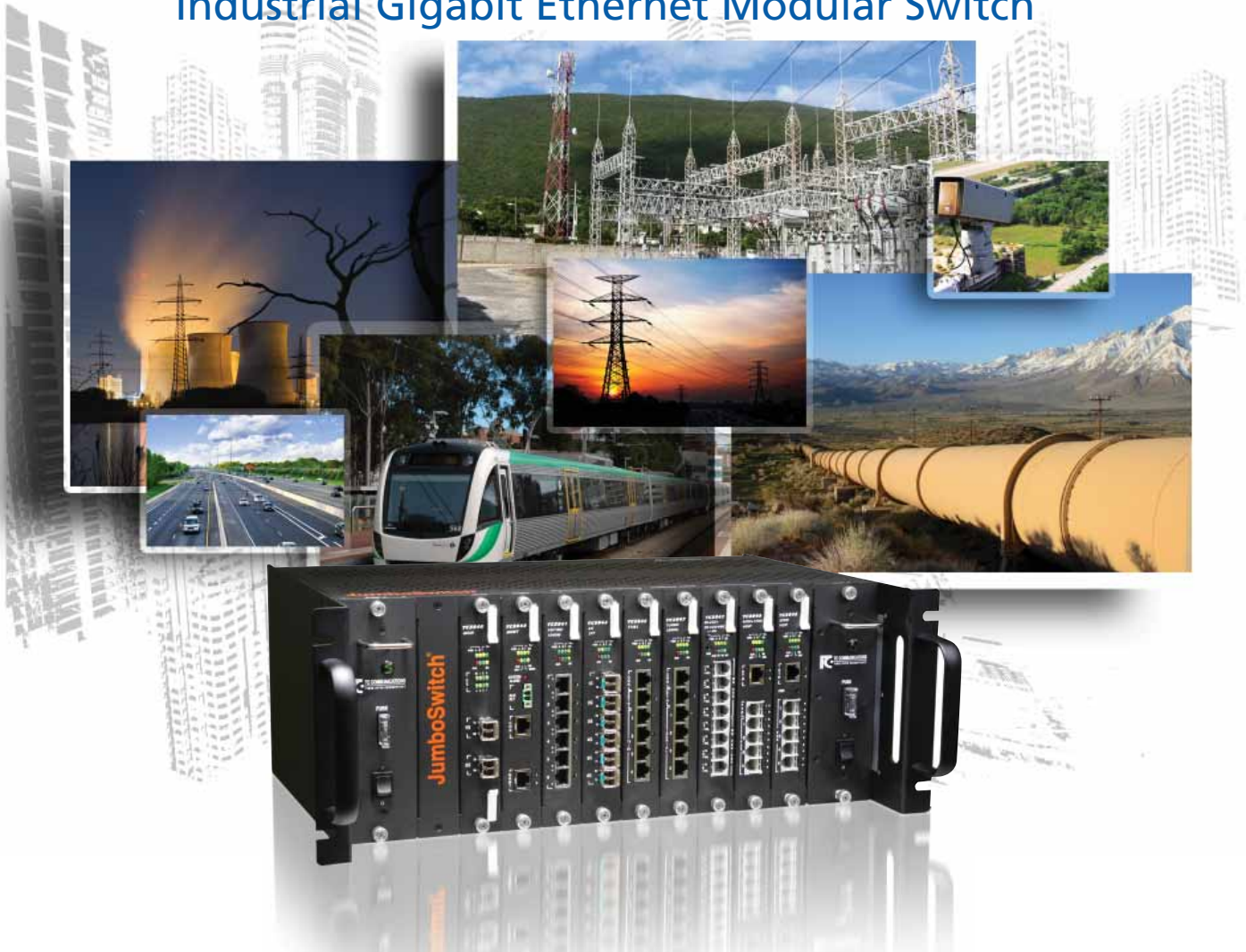

- ➔ Designed for the Harshest Industrial Environments
- ➔ Integrates Data, Voice and Delay-Sensitive Serial Traffic over Ethernet
- ➔ Provides a Viable Migration from TDM (SONET/SDH) to Ethernet
- ➔ Reliability of SONET/SDH with Simplicity of Ethernet
- ➔ Comprehensive Standards-Based Network Management

JumboSwitch - Features & Benefits



Various JumboSwitch® Chassis Styles



Ruggedized Design

- Industrial hardened (-40°C to +80°C), conformal coating, no moving parts, vibration and shock tested
- Industrial standards compliance: IEC 61850-3, IEEE 1613, NEMA TS-2

Benefits:

JumboSwitch® is substation and industrial hardened making it operational in the harshest of environments.

Flexibility

Flexible Topology support:

- Dual counter-rotating ring
- String/Bus
- Point-to-Point
- Full mesh

Benefits:

Self-healing rings provide protection against fiber cuts and loss of nodes with less than 30 ms recovery time. Point-to-Point, Mesh & String/Bus topologies offer the ultimate in flexible and efficient network designs.

Scalability

- Hot-swappable modular design
- Multiple size chassis
- Migration path to 10GigE

Benefits:

Modular design offers pay-as-you-grow scalability. With multiple chassis options, JumboSwitch® networks can be efficiently custom tailored to the customer's needs.

Ethernet design offers scalable, future proof migration to 10GigE.

VoIP+

Voice-over-IP (Distributed, Internal PABX)

Benefits:

The VoIP+™ eliminates the need for a central PABX. It supports all major features of a PABX without an external SIP server or call manager. The PABX features include: Caller ID hot-line, call transfer, call forwarding, 3-way calling, internal address book and more. A distributed virtual PABX eliminates the need for a central PABX and it eliminates a single point of failure for mission critical applications.

Network Management

- Web Based (Graphical User Interface)
- Telnet
- Serial Console
- TCView™ (Graphical SNMP-based management)

Benefits:

A flexible standards-based network management provides comprehensive Fault Management, easy Configuration, Administration, Asset Management and Security. Users have the ability to remotely monitor optical Tx & Rx power and temperature conditions.

GigE Technology

GigE backbone with migration to 10GigE

Benefits:

The Ethernet-based design of the JumboSwitch® provides a migration path and future growth without fork-lift upgrades. Any customer's investment in chassis, interface modules, power supply & NMS cards is protected.

Interface Types

Large selection of interface types for industrial applications:

- Gigabit Ethernet
- Gigabit SFP Ethernet
- DCS/SCADA
- Teleprotection
- Serial (RS-232/422/485)
- VoIP Distributed and Integrated PABX
- Dry Contact
- T1/E1-over-Ethernet
- T3/E3-over-Ethernet
- Ethernet-over-PDH(T1/E1, T3/E3, STS-1/3, STM-1)
- 2W/4W 600 Ω Analog
- G.703/64k
- C37.94

Benefits:

JumboSwitch® offers convergence of data, voice and delay-sensitive industrial applications over a single, cost-effective full-featured GigE IP network.

Ethernet Standards

- IEEE 802.1x
- IEEE 802.1w
- IEEE 802.1s
- IEEE 802.3x
- IEEE 802.1D
- IEEE 802.1p
- IEEE 802.1Q
- IEEE 802.3
- IEEE 802.3u
- IEEE 802.3z
- IEEE 802.3ab
- IEEE 802.3ad
- IEEE 802.3ah
- 10/100/1000Base-T
- 100Base-FX
- 1000Base-SX/LX

JumboSwitch - Security Features

Network security in Industrial environments such as power plants, pipelines, transportation corridors, airports, oil refineries, factory floors, etc. is extremely important. Security laps in these types of environments could potentially have devastating consequences of national proportions.

TC Communications Inc. has provided comprehensive industrial hardened network platforms, including critical security solutions, since 1992. As evidence of this commitment to security, its newly designed JumboSwitch® IP platform complies with the North American Electric Reliability Council (NERC) Critical Infrastructure Protection (CIP) requirements.

The JumboSwitch® supports the following security features:

- **Enable/Disable Ports** – The ability to disable ports to provide physical security
- **MAC Based Port Security** – Enhances Ethernet port security by limiting device access to use the port
- **802.1Q VLAN** – Separates Ethernet traffic into virtual LANs to provide physical security and improve network availability by limiting broadcast storms

- **Passwords** – Multi-Level and strong passwords to prevent unauthorized logins and user access
- **SSH** – Encrypts all transmission data for secure, remote Command-Line Interface (CLI) access over IP networks, such as Telnet
- **SSL** – Encrypts HTTP traffic for secured access to the browser-based JumboSwitch® management GUI
- **802.1x** – Works with RADIUS to only allow authenticated ports.
- **Radius** – Provides centralized user authentication and service authorization through a RADIUS server
- **Bandwidth Rate Limiting** – Enforces Ethernet port controls for traffic monitoring and prioritization to protect against unwanted traffic storm
- **SNMPv3** – Maximizes security by authenticating and encrypting JumboSwitch® management (e.g. TCView) via SNMP protocol

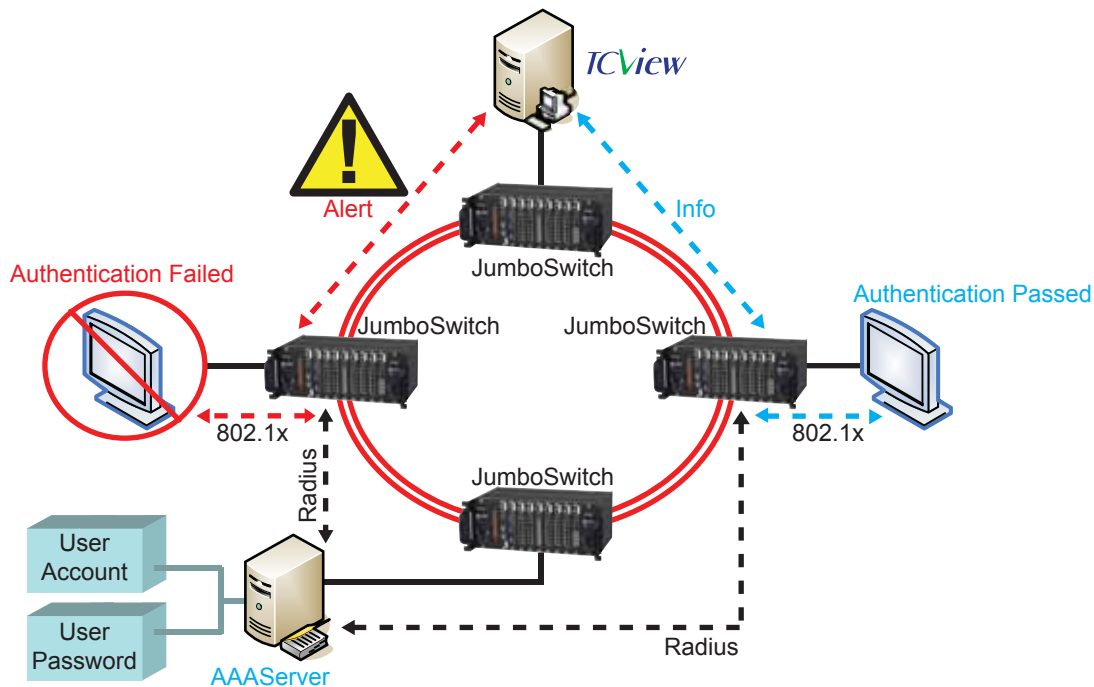

In the left section of the above diagram, an unwanted user's attempt to access the network is blocked after it fails authentication by the RADIUS AAA server. In this case, JumboSwitch® sends an alert to TCView and the failed attempted port is disabled. The right section of the diagram depicts a successful attempt by a valid user who is authenticated by the RADIUS AAA server.

JumboSwitch - Interface Cards

TC3842-1: SFP Ethernet Card

- 6-Port SFP Gigabit Ethernet Switch
- Optional 3 Ports 100Base-FX
- Single Mode, Multimode, Optional One Fiber Bi-Directional Communications
- Ethernet Rate-Limit, VLAN, QoS & More
- Network Manageable Via Web (with TC3840 MGMT card)
- Temperature & Power Consumption Monitoring

Also Available:

- TC3841: 6 Port Gigabit Copper RJ45 Card
- TC3842-2: 3-Port Gigabit SFP + 3-Port 100FX SFP Card
- TC3842-3: 6 Port 100FX SFP Card
- TC3842-4: 1-Port 10BaseFL Card

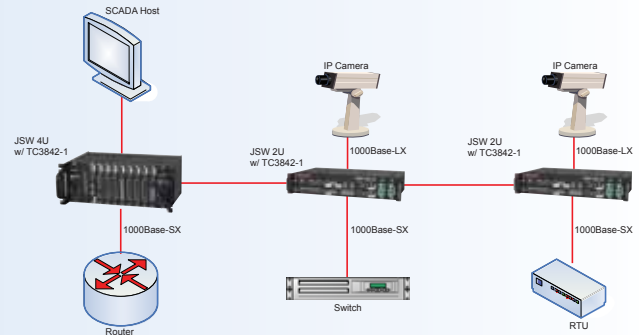

TC3844-3: Ethernet-over-T3/E3

- 1 Port Fast Ethernet Transport over Framed/Unframed T3 or E3 with QoS
- Flexible Fractional T3/E3 Support
- Ethernet and T3/E3 Statistics Monitoring
- VLAN Tagging and Priority Labeling
- Manage Via Web, SNMP, Serial Console, Telnet
- Temperature & Power Consumption Monitoring

Also Available:

- TC3844-1 Ethernet-over-T1/E1,
- TC3844-4: Ethernet-over-STS-1
- TC3844-5: Ethernet-over-STS-3

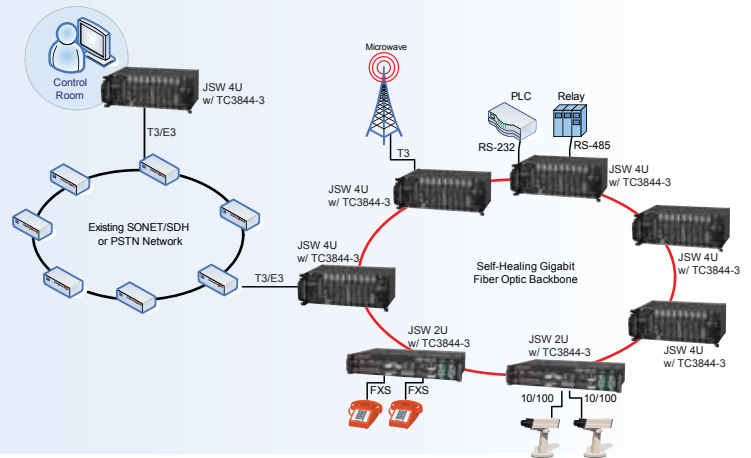

TC3845-3: T3/E3-over-IP

- Transports 1 Ch. T3/E3-over-Ethernet/IP
- Near Stratum-II Clock Precision & Extremely Low Latency
- Point-to-Point & Point-to-MultiPoint Applications
- VLAN and QoS Support
- Manage Via Web, SNMP, Serial Console, Telnet
- Temperature & Power Consumption Monitoring

Also Available:

- TC3845-1: T1/E1-over-IP (1 to 4 Ch.)

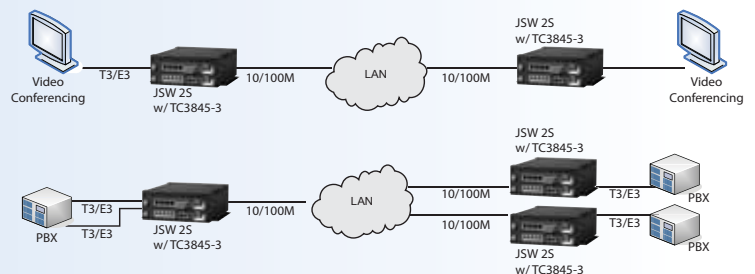

JumboSwitch - Interface Cards

TC3846-1: G.703/64K-over-IP (Co-Directional)

- Extends 2 Ch. G.703/64k Co-directional Interface-over-Ethernet
- Less Than 5 msec. Latency, One Way
- Point-to-Point & Point-to-MultiPoint Applications
- VLAN and QoS Support
- Manage Via Web, SNMP, Serial Console, Telnet
- Temperature & Power Consumption Monitoring

Also Available:

TC3846-2 C37.94-over-IP

TC3846-4 600 Ω Analog (2 or 4 Wire)

TC3846-6 4 Ch. 600 Ω Analog + 4 Ch Dry Contact (2 or 4 Wire)

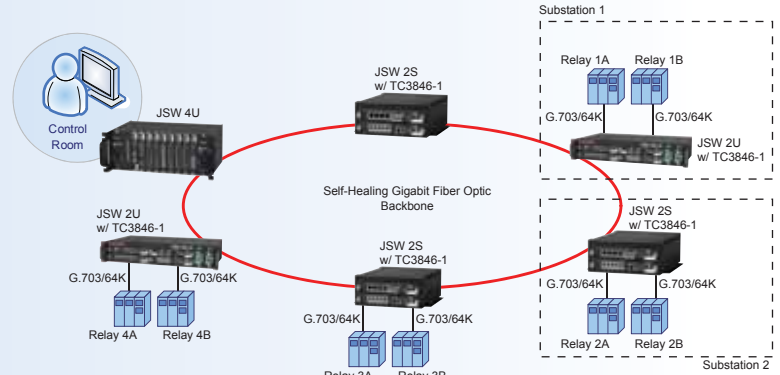

TC3847-3: 8-Ch. Turbo Serial-over-IP Card

- 4 Ch. of RS-232 & 4 Ch. of RS-422 / RS-485
- Extremely Low Latency (Supports Teleprotection Relays)
- RS-232 Ports Support Hardware Handshaking or Synchronous Mode
- Data Rates up to 115kbps
- VLAN & QoS Support
- Temperature & Power Consumption Monitoring

Also Available:

TC3847-1 4 Ch. RS-232, RS-422/485 Server

TC3847-5 Dry Contact (4 or 8 Ch.)

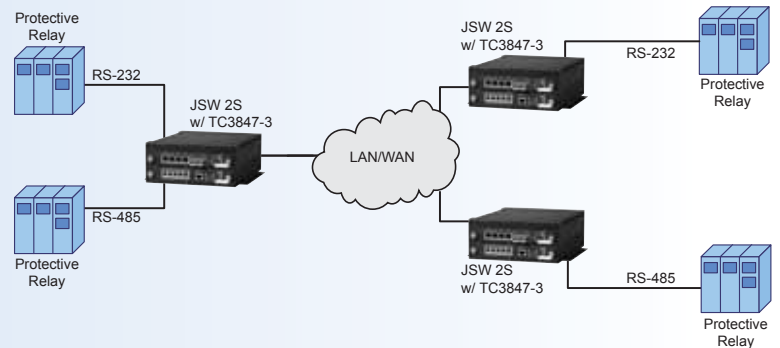

TC3848-1 VoIP+™: Virtual PBX

- 2 or 4 Port FXS + 1 Port FXO
- Call Processing Features: Caller ID, hot-line, call transfer, auto-attendant & group hunting.
- Supports Fax, Dial-up Modem & Phone
- Internal Address Book
- SIP Server
- Manage via Web, SNMP or Telnet
- Remote Firmware Upgrade

Also Available:

TC3848-2 5 Port FXO

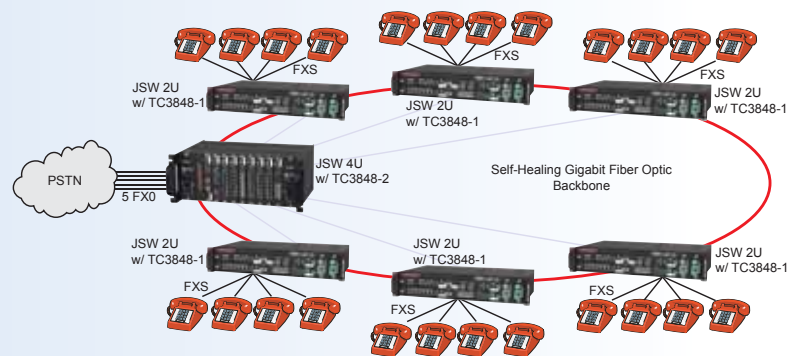

JumboSwitch - Cages & Chassis

JumboSwitch - 4U



- Ruggedized Design for Harsh Environments
- Industry Standard 19" Wide and 4U High
- Designed to Hold 1 Main Card, 1 Management Card and 7 Interface Cards
- Dual Power Supply, Mix and Match
- Power Supply Options are 24VDC, -48VDC, 115VAC, 230VAC and 240VAC (50-60Hz)

JumboSwitch - 2U



- Ruggedized Design for Harsh Environments
- Industry Standard 19" Wide and 2U High
- Designed to Hold 1 Main Card, 1 Management Card and 2 Interface Cards
- Dual Power Supply, Mix and Match
- Power Supply Options are 12VDC, 24VDC, -48VDC, 125VDC, 115VAC, 230VAC and 240VAC (50-60Hz)

JumboSwitch - 1U



- Ruggedized design for Harsh Environments
- Industry Standard 19" Wide and 1U High
- Designed to Hold 1 Main/Management Combo Card and 1 Interface Card
- Standard 12VDC Dual Load-Sharing Power Supply
- Power Supply Options are 24VDC, -48VDC, 125VDC, 115VAC, 230VAC and 240VAC (50-60Hz)

JumboSwitch - 2S



- Ruggedized Design for Harsh Environments
- Standard 12VDC Dual Load-Sharing Power Supply
- Designed to Hold 1 Main/Management Combo Card and 1 Interface Card
- Power Supply Options are 24VDC, -48VDC, 115VAC, 230VAC and 240VAC (via External AC Power Adapter)

Network Management System for TC Networking Devices



Overview:

Provides the integrated and comprehensive management tools needed to simplify the configuration, administration, monitoring,

troubleshooting, and servicing of JumboSwitch[®] networks and other TC Communications networking devices. Going beyond traditional element manager applications, it delivers a unique platform of cross-functional management capabilities that integrate all TC networking products into one network administration platform.

Key Features:

- Remote Software/Firmware download capability
- Extensive Asset Management capabilities including ongoing collection of system part/serial numbers and version numbers/upgrade dates for precise inventory management
- Remote Monitoring for "live" operating temperatures of each interface card
- Remote Monitoring for "live" power consumption of each interface card
- Remote Monitoring for "live" fiber ports Transmit & Receive power of critical fiber links

Management:

TCView supports five functional areas of network management defined by the International Organization of Standardization (ISO).

- Fault Management
- Configuration Management
- Asset Management
- Performance Management
- Security Management

Specifications:

Minimum System Hardware:

- 3.0 GHz Intel Pentium 4 or equivalent processor
- 3 GB RAM memory
- 100 GB storage
- 1000 Mbit NIC

Supported Software:

- Windows XP Professional or Vista
- Microsoft Windows 2003 or 2008 Server (32-bit)
- Microsoft SQL Server 2005 or 2008

Browser:

Microsoft Internet Explorer version 6.0 or later

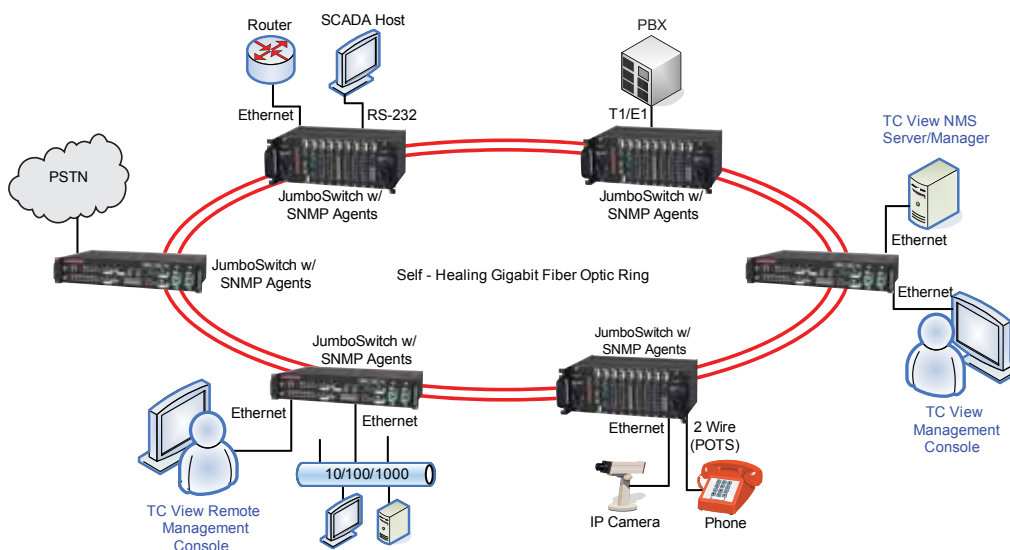

Product List

Fiber Optic Modems for Data

- TC1100 – Sync/Async RS-232 Fiber Optic Modem
- TC1200 – 3-channel Async RS-232 Fiber Optic Modem (Async with Control)
- TC1230 – Async RS-366 Dial-up Fiber Optic Modem
- TC1504 – Sync RS-422/RS-449 Fiber Optic Modem (Ext. Clock)
- TC1520 – Async RS-422/RS-485 (2/4-wire) Fiber Optic Modem
- TC1540 – RS-232, RS-422, RS-485 (2 or 4-Wire) Fiber Optic Modem
- TC1630 – T1/E1 Fiber Optic Modem
- TC1631 – T1/E1 Fiber Optic Modem (supports 1-fiber Bi-Directional & optical redundancy)
- TC1680 – T3/E3 Fiber Optic Modem
- TC1705 – Multi-Interface (RS-232, RS-422, RS-485, V.35, TTL...) Sync/Async Fiber Optic Modem
- TC1710 – High Speed Multi-Interface (RS-232, RS-422, RS-485, V.35, TTL...) Sync/Async Fiber Optic Modem
- TC1720 – High Speed RS-422/449 Fiber Optic Modem

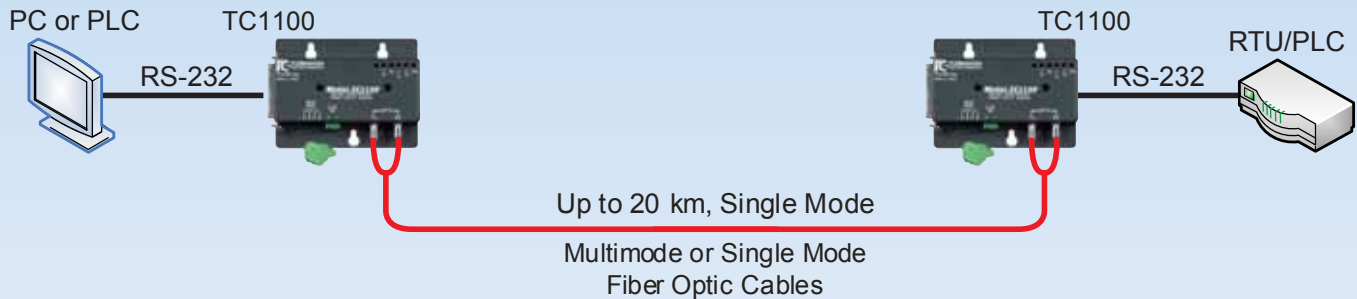

Typical Application Using TC1100 RS-232 Sync/Async Fiber Optic Modems

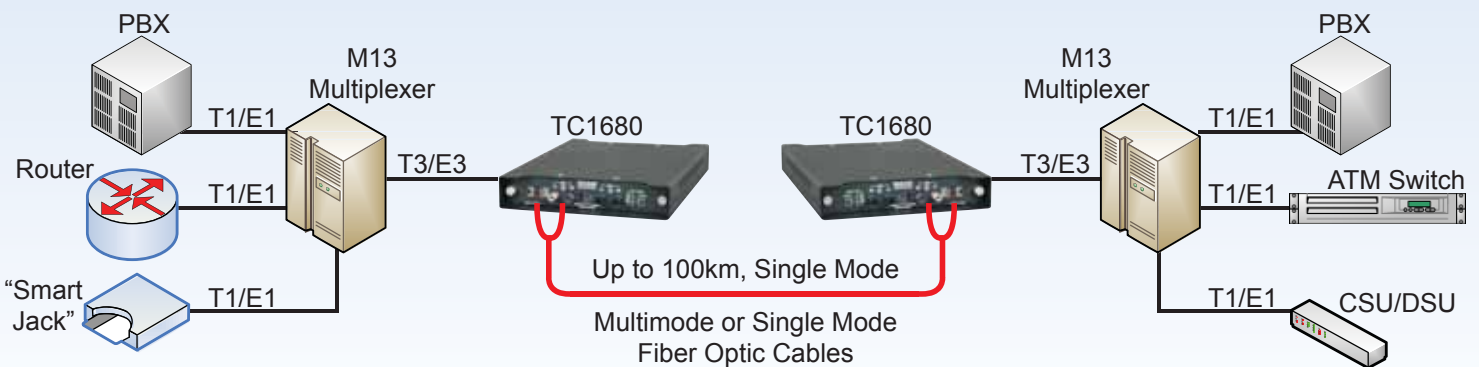

Typical Application Using TC1680S To Link M13 Multiplexers via Fiber Optics

Product List

Ethernet Media Converters, Self-Healing Fiber Switches & Serial-to-IP Converters

- TC3105 – 10Base-T to Fiber Optic Media Converter
- TC3210 – 10/100Base-T (Auto-sensing) Ethernet Fiber Optic Media Converter
- TC3240 – Switching/Bridging Ethernet Fiber Media Converter with Rate Control
- TC3300 – 10/100/1000Base-T (Auto-sensing) Ethernet Fiber Optic Media Converter
- TC3301 – 1000Base-T Ethernet Fiber Optic Media Converter
- TC3340 – 2+2 Managed Redundant Gigabit Ethernet Switch
- TC3400 – RS-232, RS-422, RS-485 to 10Base-T Ethernet Converter
- TC3420 – RS-232, RS-422, RS-485 to 10Base-T Ethernet Media Converter (Broadcast)
- TC3705 – 10/100Base-T Industrial Ethernet Fiber Optic Switch (4Tx +1Fx)
- TC3715 – 10/100Base-T Industrial Ethernet Fiber Optic Switch (6Tx +1Fx or 2Fx)
- TC3720 – Redundant Ring Industrial Ethernet Fiber Optic Switch (6Tx + 2Fx)
- TC3820 – Redundant Ring Industrial Ethernet Fiber Optic Switch (6Tx + 2Sx or 2Lx)
- TC3840 – “JumboSwitch” Industrial Gigabit Ethernet Modular Switch

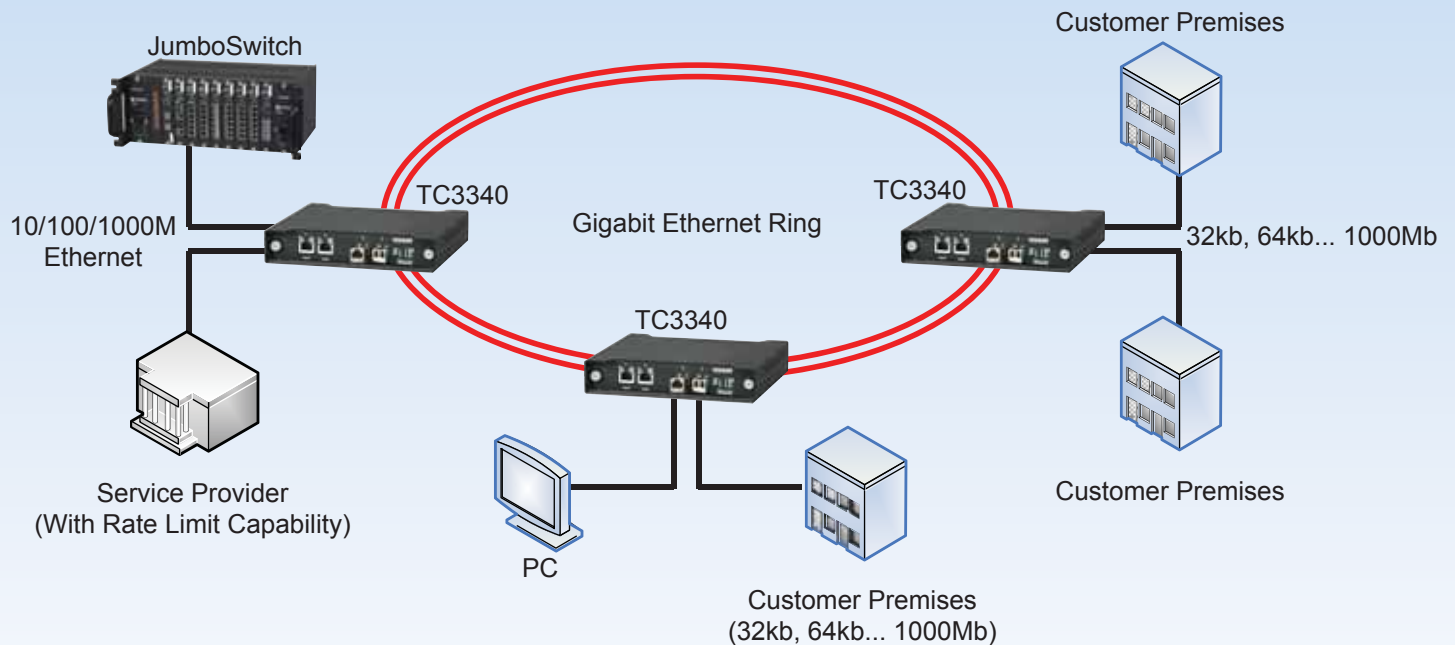

TC3340 Using the One-Fiber Bi-Directional Option to Form A Ring Network

Product List

Fiber Optic Mode Converters / Repeater & WDM & Phone Extenders

- TC3004 – “MAXI” Multimode to Single Mode Converter/Repeater (& vice versa) up to 622 Mbps
- TC3005 – “MAXI” Multimode to Single Mode Converter/Repeater (& vice versa) up to 200 Mbps
- TC3006 – “MAXI” Gigabit Fiber Optic Mode Converter/Repeater up to 1.25 Gbps
- TC3007 – “Single Fiber” Multimode-to-Single Mode Converter/Repeater (& vice versa)
- TC3021 – Fiber Optic Mode Converter (MM to SM Conversion, Low Speed, Bursty Data) 20 bps to 1 Mbps
- TC3022 – Fiber Optic Mode Converter (MM to SM Conversion, Low Speed, Bursty Data) 1 Mbps to 10 Mbps
- TC3023 – Fiber Optic Mode Converter (MM to SM Conversion, Low Speed, Bursty Data) 1200 bps to 5 Mbps
- TC3025 – Multimode to Single Mode Converter/Repeater (& vice versa) up to 50 Mbps
- TC4001 – 2 Channel Wave Division Multiplexer (WDM)
- TC1900 – “Quick-Talk” RS-232 Telephone (POTs to RS-232) Extender
- TC1901 – “Quick-Talk” Fiber Telephone (POTs to Fiber) Extender
- TC1903 – Fiber Telephone Extender (supports 1-fiber Bi-Directional)
- TC1905 – “Quick-Talk” Phone and Dry Contact Fiber Extender
- TC1910 – Telephone to 10Base-T Ethernet Extender

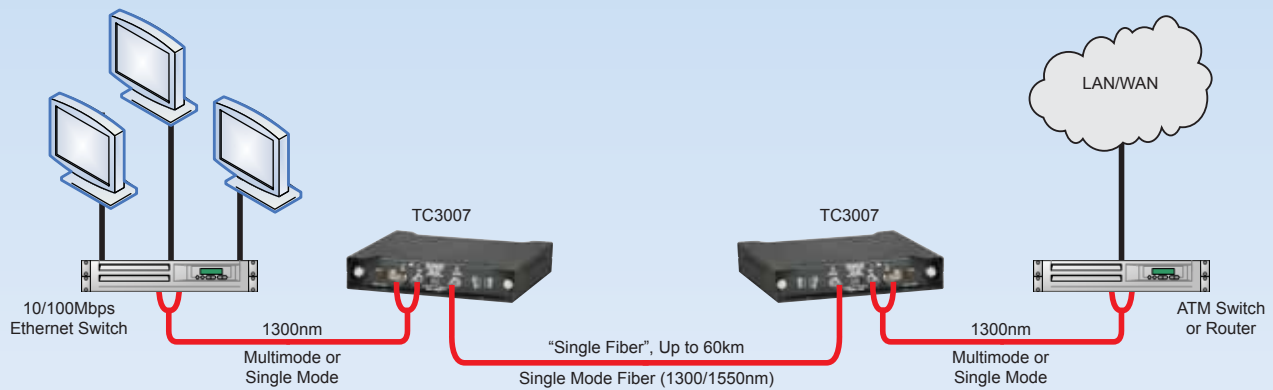

Typical Application Using TC3007 Fiber Optic Mode Converter/Repeaters.

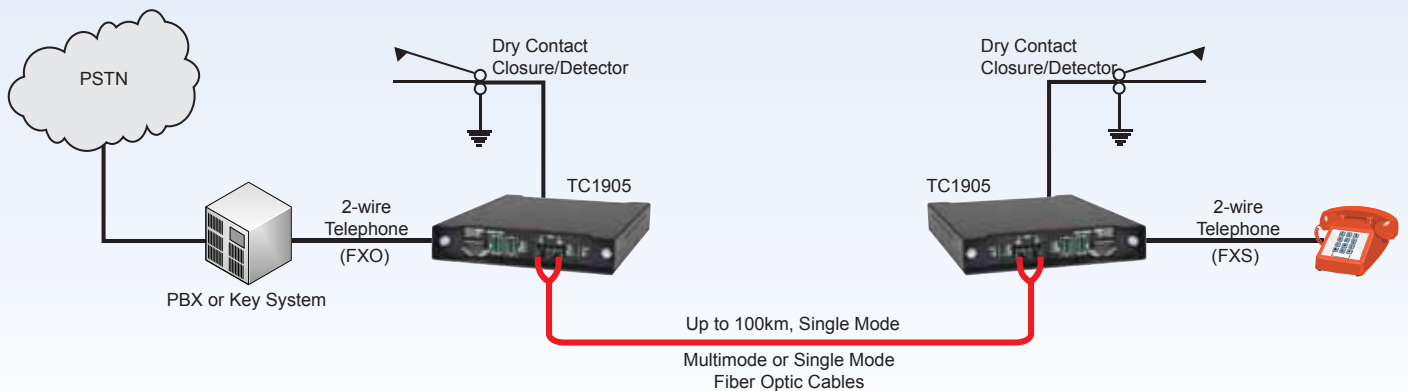

Typical Point-to-Point Application Using TC1905s to Extend Telephone and Dry Contact via Fiber Optic Cables

Product List

Self-Healing Multi-Drop Fiber Modems & Multiplexers



- TC2100 – Self-Healing Ring Multi-Drop Fiber Optic Modem
- TC2200 – Multi-Drop Bus/String Fiber Optic Modem
- TC2400 – High Speed Self-Healing Ring Multi-Drop Fiber Optic Modem
- TC2800 – 4/8/12 channel Self-Healing Ring Multi-Drop Fiber Optic Multiplexer
- TC2850/2851 – Self-Healing Multi-Drop Fiber Optic Multiplexer with Redundant Virtual Rings with Channel Mapping
- TC2850/2852 – Self-Healing Multi-Drop Fiber Optic Multiplexer with Redundant Virtual Rings with 2+2 Redundancy
- TC2900 – 4/8/12 channel Bus/String Multi-Drop Fiber Optic Multiplexer

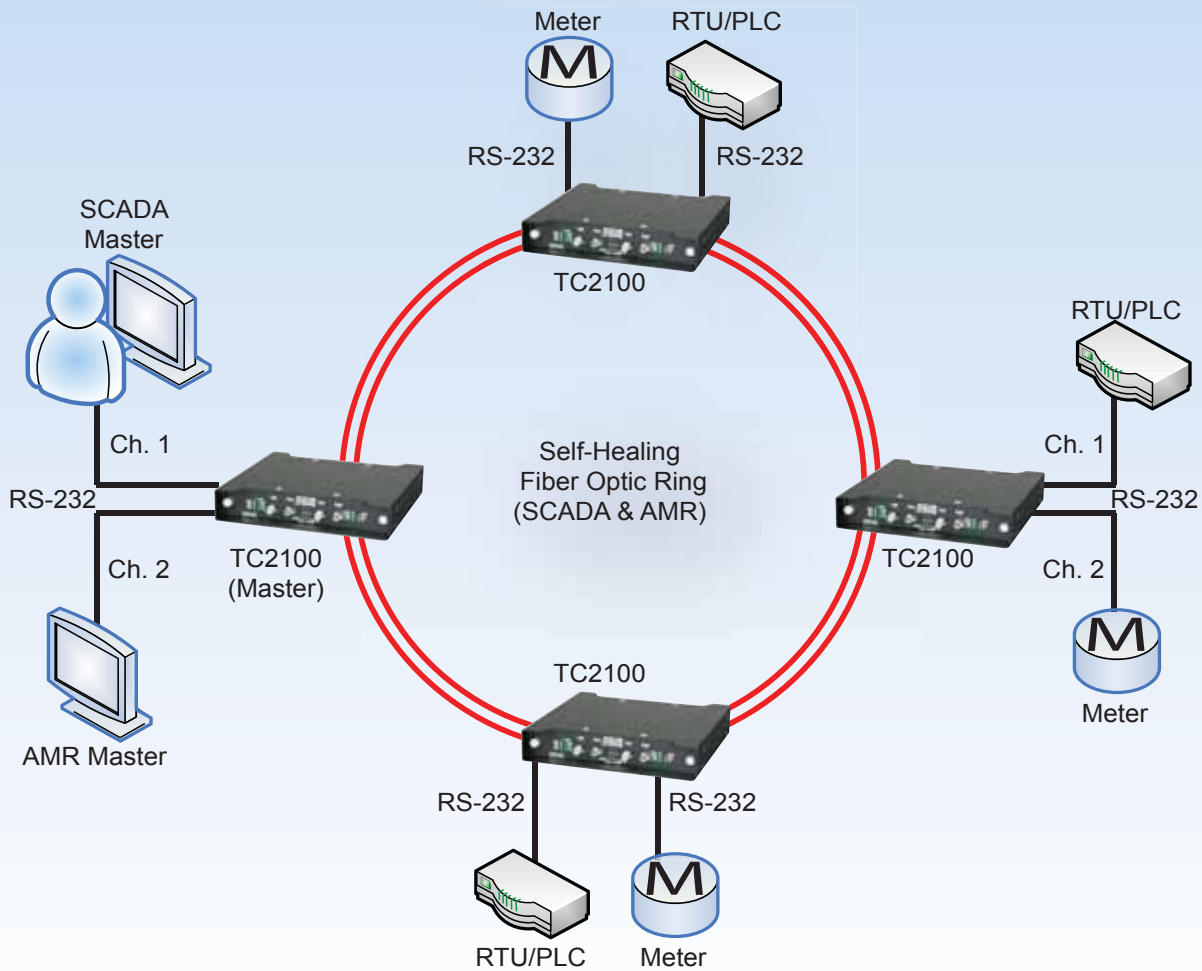

Typical Self-Healing Ring Application using the TC2100 Multi-Drop Fiber Optic Modem

Product List

Fiber Optic Multiplexers for Leased Lines, Telephones, Data & PCM



- TC1880 – RS-232 4/8 channel Async/Sync “Micro Mux”
- TC8000 – 2 to 28 channel Audio/Analog Multiplexer
- TC8108 – Stackable 8 to 128 channel Multiplexer
- TC8116 – 8/16 channel Multi-interface Multiplexer (RS-232, RS-422, RS-485, Dry contact)
- TC8300 – 1 to 4 channel T1/E1 Fiber Optic Multiplexer
- TC8510 – 1 to 4 channel T1/E1 & 10/100Base-T Fiber Optic Multiplexer
- TC8518 – 8 to 24 channel T1/E1 and 3-Ch. 10/100Base-T Fiber Optic Multiplexer
- TC8520 – Ethernet, Telephone & RS-232/422 Fiber Optic Multiplexer
- TC8530 – Ethernet & RS-232/422, TTL & Dry Contacts Fiber Optic Multiplexer
- TC8800 – 1 to 28 Channel Telephone & Data Fiber Optic Multiplexer

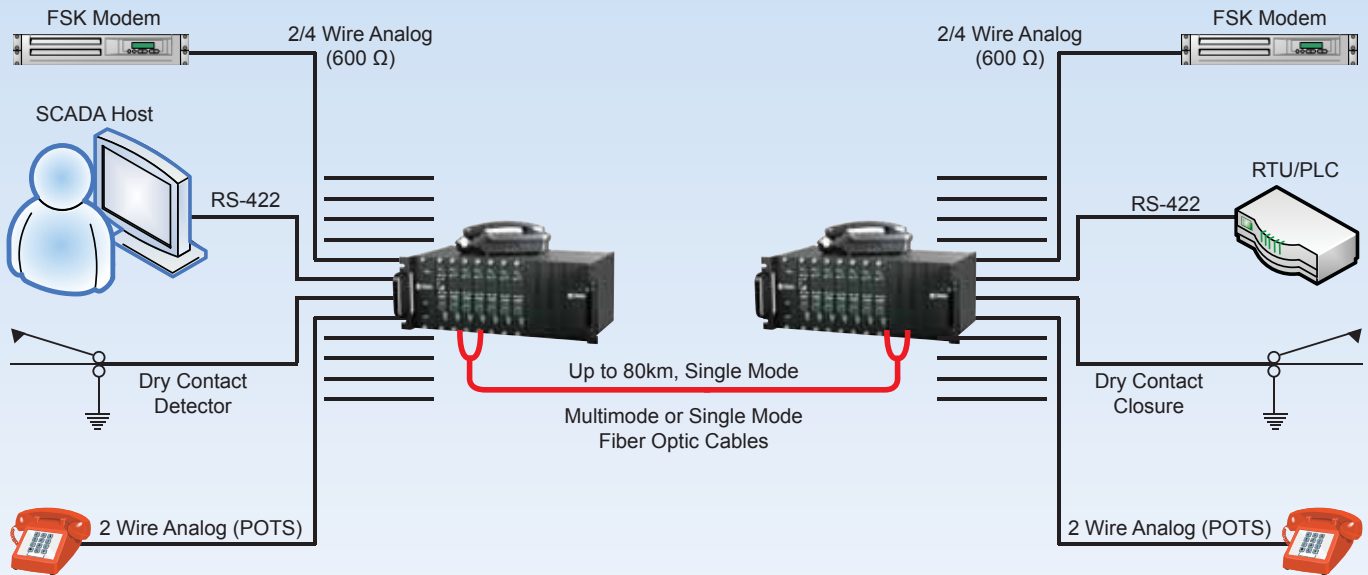

Typical Point-to-Point Application Using TC8800 Telephone/Data Fiber Optic Multiplexers

Product List

Broadcast/Receive Device & Digital Mixers

- TC8930 – 1-8 Ch. Party-Line Digital Mixer
- TC8916 – 8/16/24 Port RS-232/RS-422 Broadcast & Receive Device



Accessories

- TCRM197 – 19" Wide, 4U High Rack Mount JumboSwitch Card Cage
- TCRM198 – 19" Wide, 2U High Rack Mount JumboSwitch Card Cage
- TCRM199 – 19" Wide, 1U High Rack Mount JumboSwitch Card Cage
- TCSD11-2 – 2S Standalone/Wallmount JumboSwitch Chassis
- TCRM191/192 – 19" Wide, 4U High Universal Rack Mount Card Cage
- TCRM195/196 – 19" Wide, 1U High Universal Rack Mount Card Cage
- TC3PS (AC/DC) - Power Cube

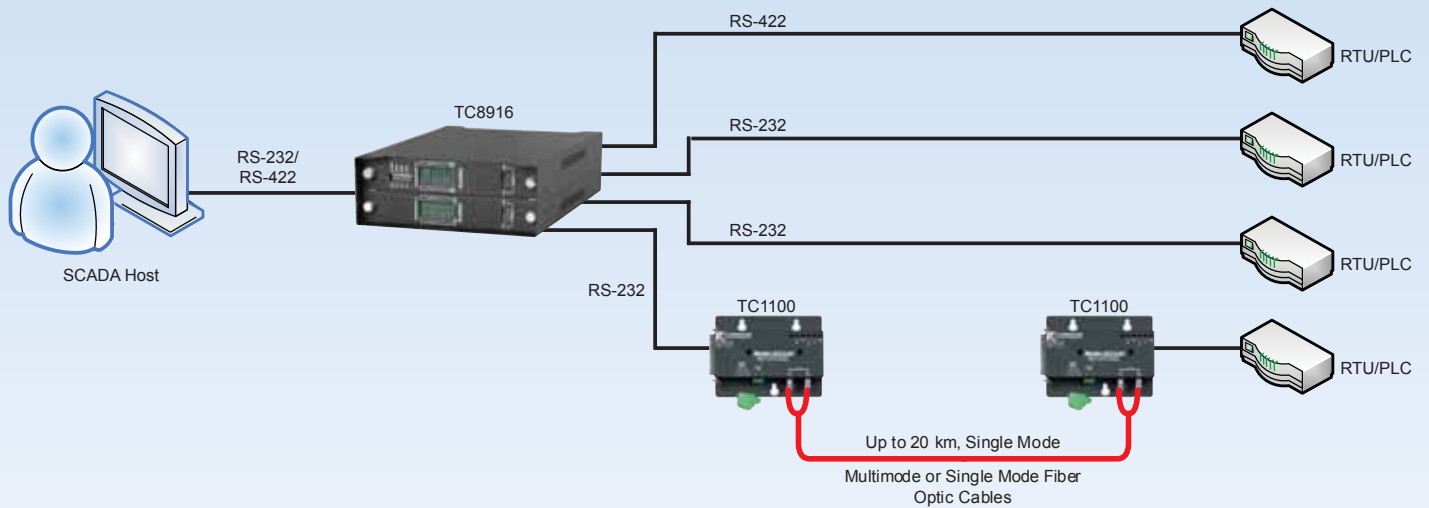

Typical SCADA Application Using TC8916 Broadcast and Receive Device

Product Details

Fiber Optic Modems for Data

	Specs \ Model No.	TC1100	TC1200	TC1230	TC1504	TC1520
Optical Options	MM (850 or 1310nm)	Yes	Yes	Yes	Yes	Yes
	MM- 1Fiber (WDM)					
	SM (1310 or 1550nm)	Yes	Yes	Yes	Yes	Yes
	SM - 1Fiber (WDM)					
	Optical Redundancy					
	Serial Data	RS-232	RS-232 (DCE only)	RS-366 (DCE Only)	RS-422/449	RS-422/485
Electrical Interfaces	Max. Baud Rate (bps)	Sync: 128K Async: 64K	Async: 120K w/ Handshake (RTS, CTS, DTR, DSR, CD)	Async: 56K (w/11 Controls)	Sync : 2M	Async: 500K
	PCM/PDH Voice & Audio					
Temperature Options (Standard -10 ~ +50°C)	Hi-Temp (-20 ~ 70°C)	Yes	Yes	Yes	Yes	Yes
	Extreme Temp. (-40 ~ 80°C)					
Packaging Options	Pocket Rocket	RB/MB	RB/MB	RB/MB	RB/MB	RB/MB
	SA-Standalone					
	Rackmount Card					

RB: Regular Base

MB: Mount-hole Base



TC1540	TC1630	TC1631	TC1680	TC1705	TC1710	TC1720
Yes	Yes	Yes	Yes	Yes	Yes	Yes
		Yes	Yes	Yes		
Yes	Yes	Yes	Yes	Yes	Yes	Yes
		Yes	Yes	Yes		
		Yes	Yes	Yes	Yes	Yes
RS-232/422/ 485				RS-232/ 422/485/ 530/V.35/TTL	RS-422/485/ 530/V.35/TTL	RS-449/422
Async: 500K				RS-232 Sync/ Async:128K RS-422 /485/530/TTL Sync/Async: 256K	Async: 10M Sync: 5M	Async: 10M Sync: 5M
	T1/E1	T1/E1	T3/E3			
Yes	Yes	Yes	Yes	Yes	Yes	Yes
	Yes	Yes	Yes	Yes	Yes	Yes
RB/MB	MB					
	Yes	Yes	Yes	Yes	Yes	Yes
	Yes	Yes	Yes	Yes	Yes	Yes



Product Details

Ethernet Media Converters, Self Healing Fiber Switches, Serial-to-IP Converters

	Specs \ Model No.	TC3105	TC3210	TC3240	TC3300	TC3301	TC3340
	Function	10BaseT Media Converter	Auto Sensing Media Converter	MC/Switch w/Rate Control	Auto Sensing GigE Media Converter	GigE Media Converter	Managed Gigabit 2+2 Ethernet Switch
Optical Options	Optical Interface/No.	1 Port	100BaseFX 1 Port	100BaseFX 1 Port	1000Base-T 1 Port	1000Base-T 1 Port	1000Base SX/LX 2 Port SFP
	MM (850 or 1310nm)	Yes	Yes	Yes	Yes	Yes	Yes
	MM- 1Fiber (WDM)		Yes	Yes	Yes	Yes	Yes
	SM (1310 or 1550nm)	Yes	Yes	Yes	Yes	Yes	Yes
	SM - 1Fiber (WDM)		Yes	Yes	Yes	Yes	Yes
Electrical Interfaces	TX Rate/ No	10Base TX 1 Ch	10/100Base TX 1 Ch	10/100Base TX 3 Ch	10/100/1000 Base TX 1 Ch	1000 Base TX 1 Ch	10/100/1000 BaseTX 2 Ch
Temperature Options (Standard -10 ~ +50°C)	Hi-Temp (-20 ~ 70°C)	Yes	Yes	Yes	Yes	Yes	Yes
	Extreme Temp. (-40 ~ 80°C)		Yes	Yes	Yes	Yes	Yes
Packaging Options	Pocket Rocket	RB/MB					
	SA-Standalone	Yes	Yes	Yes	Yes	Yes	Yes
	Rackmount Card	Yes	Yes	Yes	Yes	Yes	Yes

RB: Regular Base

MB: Mount-hole Base



TC3400	TC3420	TC3705	TC3715	TC3720	TC3820	TC3840
Point-to-Point Serial-IP Converter (10BaseTX)	Point-to-Multi Serial-IP Converter (10BaseTX)	10/100 BaseTX Auto Sensing Fiber Switch	10/100 BaseTX Auto Sensing Fiber Switch	Self Healing Multi-Drop Fiber Switch	GigE Self Healing Multi-Drop Fiber Switch	JumboSwitch Industrial Gigabit Ethernet Modular Switch
NA	NA	100BaseFX 1 Port	100BaseFX 1 or 2 Ports	100BaseFX 2 Ports	1000Base SX/LX 2 Ports	1000 SX/LX Up-link 2 Ports
		Yes	Yes	Yes	Yes	Yes
		Yes	Yes	Yes	Yes	Yes
		Yes	Yes	Yes	Yes	Yes
		Yes	Yes	Yes	Yes	Yes
RS-232/422/485 @57.6Kbps to 10BaseTX	RS-232/422/485 @57.6Kbps to 10BaseTX	10/100 BaseTX 4 Ch	10/100 BaseTX 6 Ch	10/100 BaseTX 6 Ch	10/100 BaseTX 6 Ch	10/100/1000 BaseTX Max. 42 Ch
Yes	Yes	Yes	Yes	Yes	Yes	Yes
		Yes	Yes	Yes	Yes	Yes
Yes	Yes	Yes				Yes
Yes	Yes	Yes	1U X 19"	1U X 19"	1U X 19"	Yes



Product Details

Self Healing Multi-Drop Fiber Modems & Multiplexers

	Specs \ Model No.	TC2100	TC2200	TC2400
	Self Healing Fiber Topology	Ring	Bus/String	Ring
Optical Options	MM (850 or 1310nm)	Yes	Yes	Yes
	SM (1310 or 1550nm)	Yes	Yes	Yes
	Optical Redundancy	Yes	Yes	Yes
Electrical Interfaces	Serial Data	RS-232/422/485	RS-232/422/485	RS-232/422/485
	Channels	2	2	2
	Max. Baud Rate (bps)	Async:38.4K	Async:38.4K	Async: up to 1M
Temperature Options (Standard -10 ~ +50°C)	Hi-Temp (-20~70°C)	Yes	Yes	Yes
	Extreme temp. (-40~80°C)	Yes	Yes	Yes
Packaging Options	Pocket Rocket			
	SA-Standalone	Yes	Yes	Yes
	Rackmount Card	Yes	Yes	Yes



TC2800	TC2850/51	TC2850/52	TC2900
Ring	Redundant Virtual Rings w/ Channel Mapping	Redundant Virtual Rings w/ 2+2 Redundancy	Fiber Bus/String
Yes	Yes	Yes	Yes
Yes	Yes	Yes	Yes
Yes	Yes	Yes	Yes
RS-232/422/485	RS-232/422/485	RS-232/422/485	RS-232/422/485
4/8/12	Master: 4/8/12 Slave: 4/8/12	Master: 4/8/12 Slave: 4	4/8/12
Async:38.4K	Async:120K	Async:120K	Async:38.4K
Yes	Yes	Yes	Yes
Yes	Yes	Yes	Yes
Yes	Yes	Yes	Yes
Yes	Yes	Yes	Yes



Product Details

Fiber Optic Mode Converters / Repeaters, WDM & Phone Extenders

	Specs \ Model No.	TC3004	TC3005	TC3006	TC3007	TC3021
	Function	Mode Converter Repeater Ethernet. Token Ring OC1/OC3/OC12, ATM, FDDI	Mode Converter Repeater Ethernet. Token Ring OC1/OC3, ATM, FDDI	Mode Converter Repeater Gigabit Ethernet	Mode Converter w/WDM Ethernet. Token Ring OC1/OC3, ATM, FDDI	Low Speed Mode Converter
Optical Options	MM (850 or 1310nm)	Yes (1310nm Only)	Yes (1310nm Only)	Yes	Yes (1310nm Only)	Yes
	MM-1Fiber (WDM)			Yes		
	SM (1310 or 1550nm)	Yes	Yes	Yes	Yes	Yes
	SM - 1Fiber (WDM)			Yes	Yes	
	Max. Data Rate (bps) & Characteristics	622M Continuous	10M ~ 200M Continuous	1.25 G Continuous	10M ~ 200M Continuous	30 ~ 1M Bursty or Continuous
Electrical Interfaces		NA	NA	NA	NA	NA
Temperature Options (Standard -10 ~ +50°C)	Hi-Temp (-20 ~ 70°C)	Yes	Yes	Yes	Yes	Yes
	Extreme Temp. (-40 ~ 80°C)					Yes
Packaging Options	Pocket Rocket					
	SA-Standalone	Yes	Yes	Yes	Yes	Yes
	Rackmount Card	Yes	Yes	Yes	Yes	Yes



TC3022	TC3023	TC3025	TC4001	TC1900	TC1901	TC1903	TC1905	TC1910
Mode Converter Repeater	Low Speed Mode Converter	Mode Converter Repeater	WDM Fiber Doubler	RS-232 Telephone Extender	Fiber Telephone Extender	Fiber Telephone Extender	"Quick-Talk" Phone and Dry Contact Fiber Extender	Ethernet Telephone Extender
Yes	Yes (850nm Only)	Yes (1310nm Only)			Yes	Yes	Yes	
		Yes				Yes	Yes	
Yes	Yes	Yes	Yes		Yes	Yes	Yes	
		Yes	Yes			Yes	Yes	
1M ~ 10M Bursty or Continuous	1.2K ~ 5M Bursty or Continuous	500K ~ 50M Continuous	NA	Audio: 300~3.4KHz RS-232: 9.2K~64K	Audio: 300~3.4KHz RS-232: 9.2K~64K	Audio: 300~3.4KHz	Audio: 300~3.4KHz	Audio: 300~3.4KHz Ethernet: 10BaseTX
NA	NA	NA	NA	FXO/FXS, 2 or 4 Wire Analog	FXO/FXS, 2 or 4 Wire Analog	FXO/FXS, 2 or 4 Wire Analog	FXO/FXS, Dry Contact	FXO/FXS, 2 or 4 Wire Analog
Yes	Yes	Yes	Yes	Yes	Yes	Yes	Yes	Yes
Yes							Yes	
Yes	Yes	Yes	Yes	Yes	Yes	Yes	Yes	Yes
Yes	Yes	Yes	Yes	Yes	Yes	Yes	Yes	Yes



Product Details

Fiber Optic Multiplexers for Leased Lines, Telephones, Data & PCM

	Specs \ Model No.	TC1880	TC8000	TC8108	TC8116
	Function	Micro Fiber Optic Multiplexer	Analog, Intercom & Data Multiplexer	8 to 128 "Channel Stacker"	Multi-Interface Multiplexer
Optical Options	MM (850 or 1310nm)	Yes	Yes	Yes	Yes
	MM- 1Fiber (WDM)		Yes	Yes	Yes
	SM (1310 or 1550nm)	Yes	Yes	Yes	Yes
	SM- 1Fiber (WDM)		Yes	Yes	Yes
	Optical Redundancy		Yes	Yes	Yes
Electrical Interfaces	Serial Data	RS-232	RS-232/422/TTL	RS-232/422/485/TTL	RS-232/422/485/TTL
	Max. Baud Rate (bps)	Async or Sync: 56K	Async:19.2K	Async: 32Ch 38.4K Async: 64Ch 19.2K Async: 128Ch 16K	Async or Sync: 38.4K
	PCM/PDH				
	Voice & Audio		2 or 4 Wire Analog Leased Line (FSK Modem) Intercom		2 or 4 Wire Analog Leased Line (FSK Modem)
	Dry Contact Detector/Closure		Yes	Yes	Yes
	Channels	Async: 8 Ch Sync: 4	4 ~ 28	8 ~ 128	8 or 16
Temperature Options (Standard -10 ~ +50°C)	Hi-Temp (-20 ~ 70°C)	Yes	Yes	Yes	Yes
	Extreme Temp. (-40 ~ 80°C)				
Packaging Options	Pocket Rocket	RB/MB			
	SA-Standalone		Yes	Yes	Yes
	Rackmount Card		Yes	Yes	Yes

RB: Regular Base

MB: Mount-hole Base

TC8300	TC8510	TC8518	TC8520	TC8530	TC8800S/R
T1/E1 Multiplexer	T1/E1 Multiplexer w/ Ethernet Bridge	8 ~ 24 ChT1/E1 Multiplexer w/ Ethernet Switch	Telephone, Data Multiplexer w/ Ethernet Switch	Data & Ethernet Multiplexer	4 ~ 28 Ch Phone & Data Multiplexer
Yes	Yes	Yes	Yes	Yes	Yes
Yes	Yes	Yes	Yes	Yes	Yes
Yes	Yes	Yes	Yes	Yes	Yes
Yes	Yes	Yes	Yes	Yes	Yes
Yes	Yes	Yes	Yes	Yes	Yes
RS-232/422 TTL	RS-232/422/ TTL		RS-232/422/ TTL	RS-232/422/ TTL	RS-232/422/ TTL
Serial Async: 56K	10/100 BaseTX: 10M RS-232: 120K Async 64K Sync RS-422: 1M	10/100 BaseTX: 100M Total Consol Port 9.6K	Phone: 300 ~ 3.4Khz, 10/100 BaseTX: 10M, Serial: 128K Async 64K Sync	10/100 BaseTX: 10M Serial: 128K Async 64K Sync	Telephone: 300 ~ 3.4Khz Serial: 19.2K
T1/E1	T1/E1	T1/E1			
			FXS/FXO 2 or 4 Wire Analog Leased Line (FSK Modem)		FXS/FXO 2 or 4 Wire Analog Leased Line (FSK Modem)
Yes	Yes	Yes	Yes	Yes	Yes
T1/E1: 1 ~ 4 Ch Serial: 4 ~ 8 Ch	T1/E1: 4 Ch 10/100 BaseTX:1Ch Serial: 4 Ch	E1: 4/8/16/20 Ch T1: 4/8/16 /20/24 Ch 10/100 BaseTX: 3 Ch	Telephone: 1 ~ 4 Ch Serial: 4 Ch 10/100BaseTX: 1 Ch	Serial: 4/8/12 Ch 10/100 BaseTX: 1 Ch	Telephone: 4 ~ 28 Ch Serial: 4 ~ 28 Ch
Yes	Yes	Yes	Yes	Yes	Yes
	Yes	Yes	Yes	Yes	
Yes	Yes		Yes	Yes	Yes
Yes	Yes	Yes	Yes	Yes	Yes

Specializing in Industrial Fiber Communications



17881 Cartwright Road, Irvine, Ca 92614 U.S.A.
Tel: +1 (949) 852-1972 • Fax +1 (949) 852-1948
Sales: +1 (800) 569-4736 • E-mail: info@tccomm.com
TCcomm.com • JumboSwitch.com



• All Products are Designed and Manufactured in Irvine, CA. U.S.A. Since 1992